

ENGINE PROPER

1. Cylinder Head Cover

- Lightweight yet high-strength aluminum head covers are used.
- An oil filler housing has been provided on the left bank cylinder head cover to improve the serviceability when filling the engine oil.
- The cylinder head cover gasket and a gasket to seal the ignition coil circumference have been integrated to reduce the number of parts.

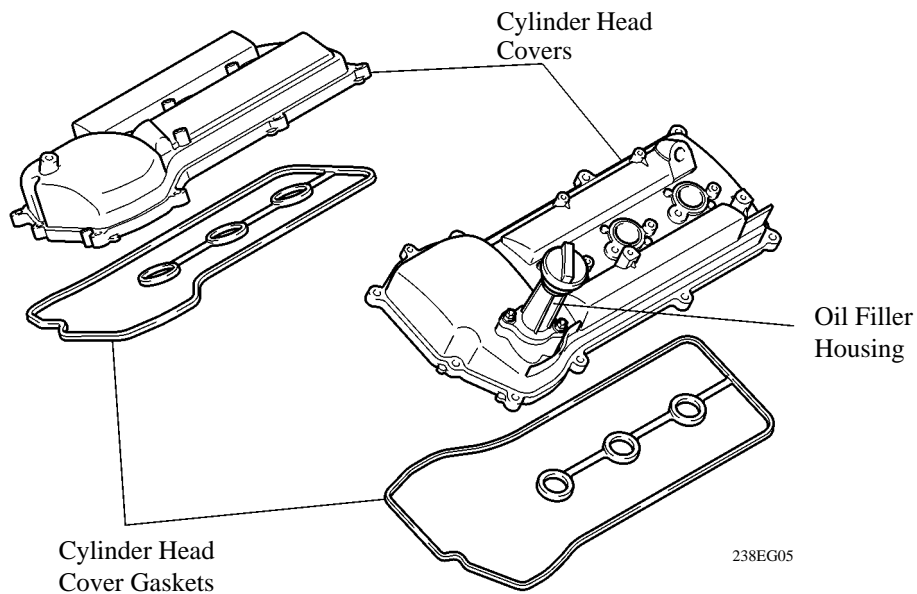

NF

2. Cylinder Head Gasket

- A steel-laminate type cylinder head gasket has been adopted.
- A shim has been added around the cylinder bore to increase the sealing surface, thus improving the sealing performance and durability.

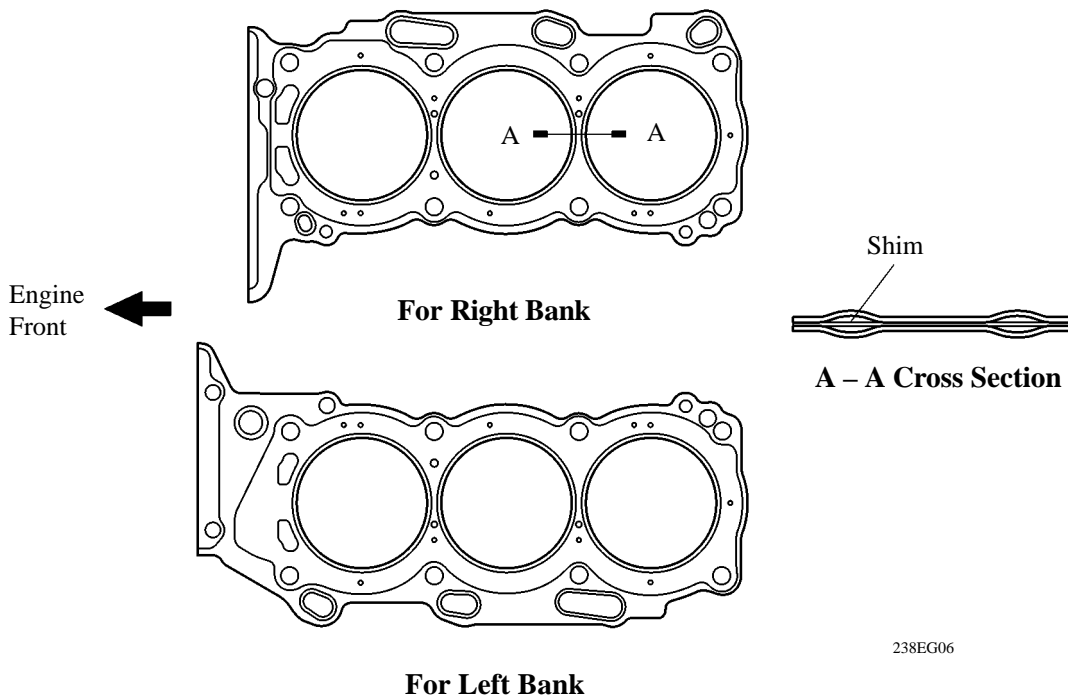

3. Cylinder Head

- The cylinder head, which is made of aluminum, contains a pentroof-type combustion chamber. The spark plug has been located in the center of the combustion chamber in order to improve the engine's anti-knocking performance.
- The intake ports are on the inside and the exhaust ports on the outside of the left and right banks respectively.
- Upright intake ports are used to improve the intake efficiency.
- A taper squish combustion chamber is used to improve anti-knocking performance and intake efficiency. In addition, engine performance and fuel economy have been improved.
- The siamese type intake port has been adopted to reduce the overall surface area of the intake port walls. This prevents the fuel from adhering onto the intake port walls, thus reducing HC exhaust emissions.

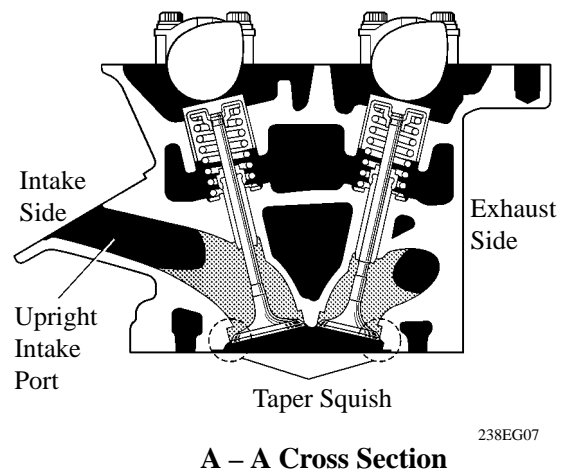
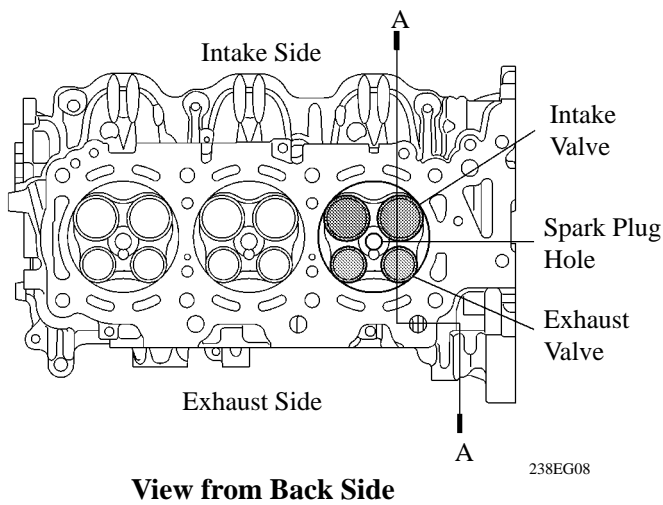

– REFERENCE –

Siamese Type

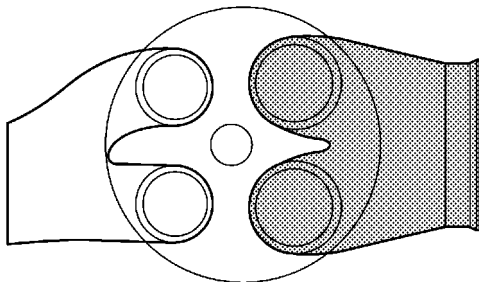

215EG18

Independent Type

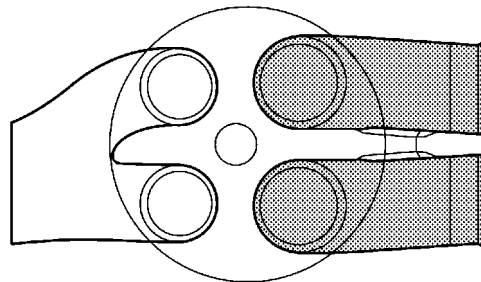

215EG19

- The cylinder head bolts have been positioned below the camshaft journal in the front of the right bank, and the holes for placing the bolts have been provided above the camshaft journal. Thus, the front end of the right bank has been shortened, resulting in a shorter overall length of the engine.

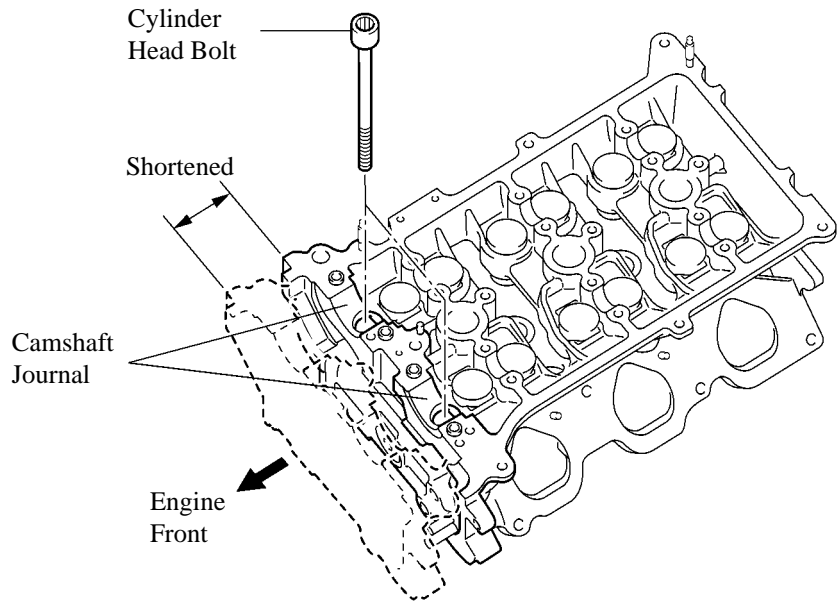

238EG09

Right Bank Cylinder Head

4. Cylinder Block

- The cylinder block is made of aluminum alloy.
- The cylinder block has a bank angle of 60°, a bank offset of 36.6 mm (1.441 in.) and a bore pitch of 105.5 mm (4.15 in.), resulting in a compact block in its length and width even for its displacement.
- Installation bosses of the two knock sensors are located on the inner side of left and right banks.

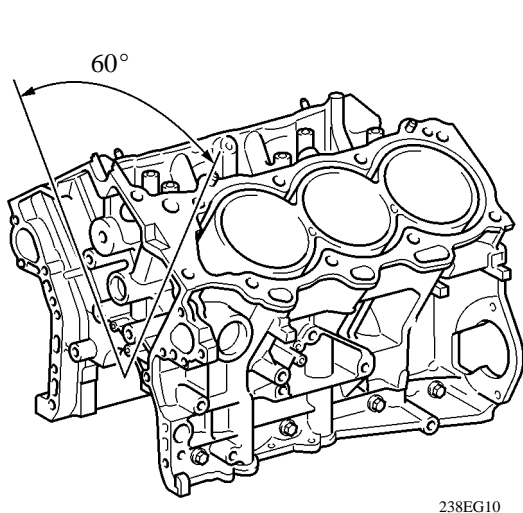

238EG10

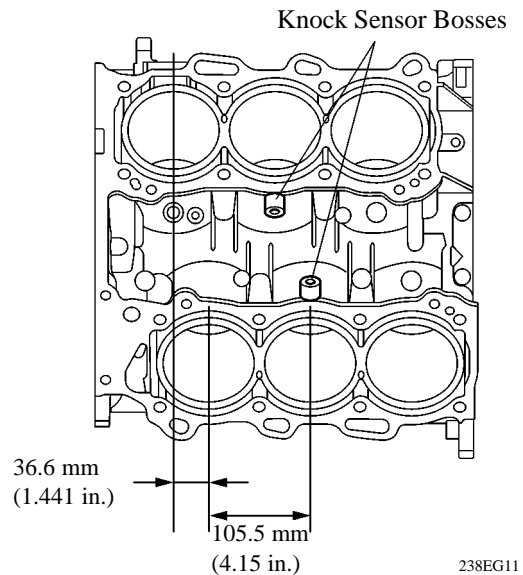

238EG11

View from Top Side

- A water passage has been provided between the cylinder bores. By allowing the engine coolant to flow between the cylinder bores, this construction enables the temperature of the cylinder walls to be kept uniform.

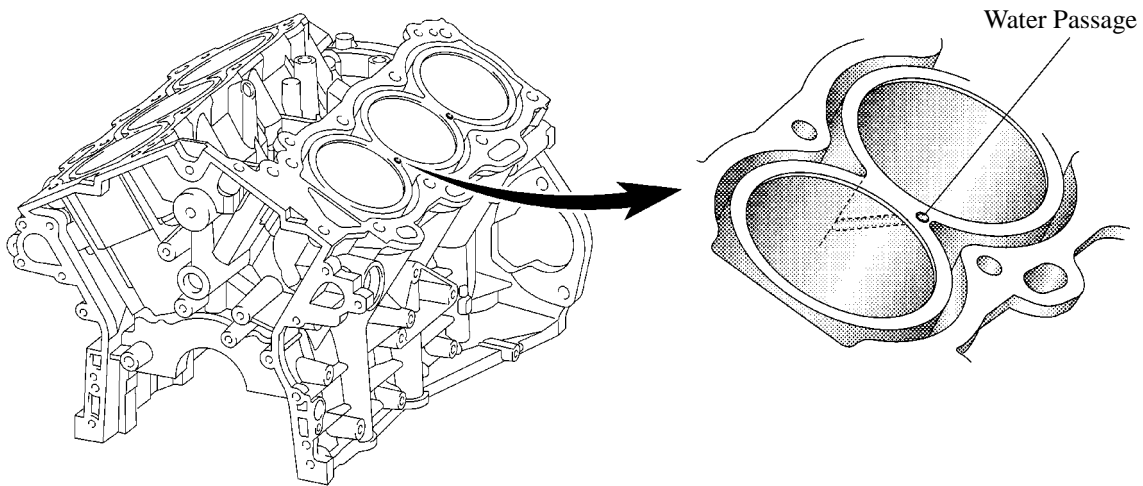

238EG12

- A compact block has been achieved by producing the thin cast-iron liners and cylinder block as a unit. It is not possible to bore the block with this liner.
- The liners are the spiny-type, which have been manufactured so that their casting exterior forms a large irregular surface in order to enhance the adhesion between the liners and the aluminum cylinder block. The enhanced adhesion helps improve heat dissipation, resulting in a lower overall temperature and heat deformation of the cylinder bores.

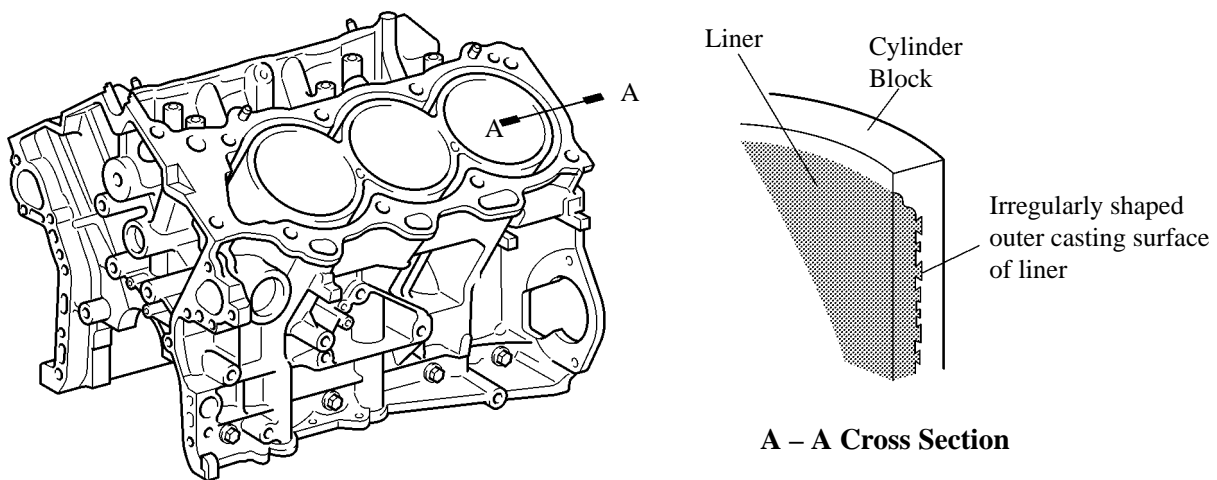

238EG13

5. Piston

- The piston is made of aluminum alloy.
- The piston head portion uses a taper squish shape to accomplish fuel combustion efficiency.
- The piston skirt has been coated with resin to reduce the friction loss.
- The groove of the top ring has been coated with anodic oxide to improve wear resistance and rust resistance.
- This piston is common to all cylinders. Therefore, the pistons are not shaped especially for the right or the left bank. As a result, serviceability has been improved.
- By increasing the machining precision of the cylinder bore diameter, the outer diameter of the piston has been made into one size.

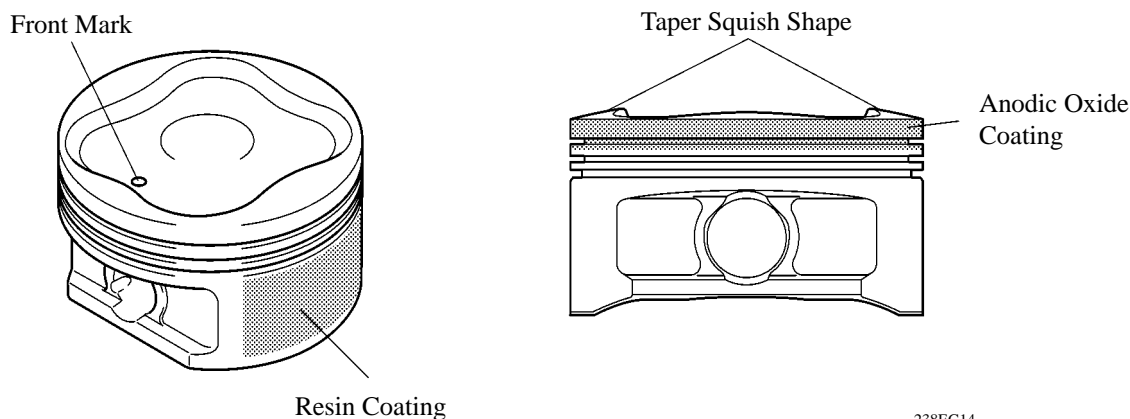

238EG14

NF

6. Connecting Rod and Connecting Rod Bearing

- Connecting rods that have been forged for high strength are used for weight reduction.
- Knock pins are used at the mating surfaces of the bearing caps of the connecting rod to minimize the shifting of the bearing caps during assembly.
- Plastic region tightening bolts are used.
- An aluminum bearing is used for the connecting rod bearings.
- The lining surface of the connecting rod bearing has been micro-grooved to realize an optimal amount of oil clearance. As a result, cold-engine cranking performance has been improved and engine vibrations have been reduced.

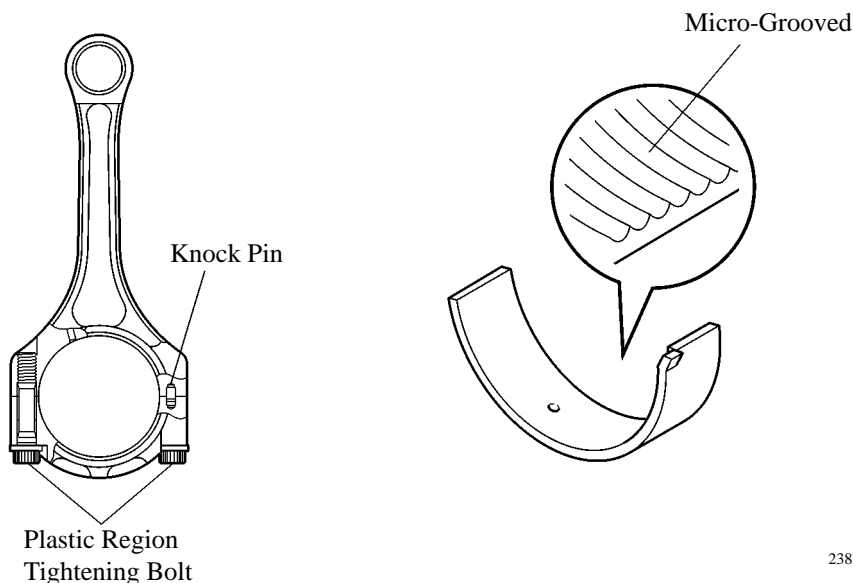

238EG15

7. Crankshaft

- A crankshaft made of steel, which excels in rigidity and wear resistance, is used.
- The crankshaft has 4 journals and 9 balance weights.
- All pin and journal fillets are roll-finished to maintain adequate strength.

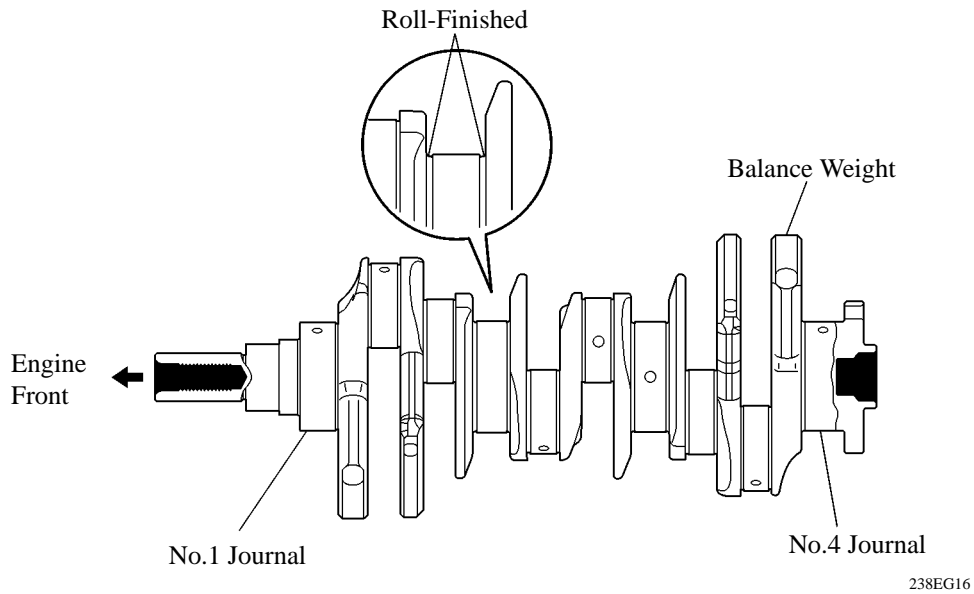

8. Crankshaft Bearing and Crankshaft Bearing Cap

- The crankshaft bearing is made of aluminum alloy.
- Similar to the connecting rod bearings, the lining surface of the crankshaft bearings has been micro-grooved to realize an optimal amount of oil clearance. As a result, cold-engine cranking performance has been improved and engine vibrations have been reduced.
- The upper main bearing has an oil groove around its inside circumference.
- The crankshaft bearing caps are tightened using 4 plastic-region tightening bolts for each journal. In addition, each cap is tightened laterally to improve its reliability.

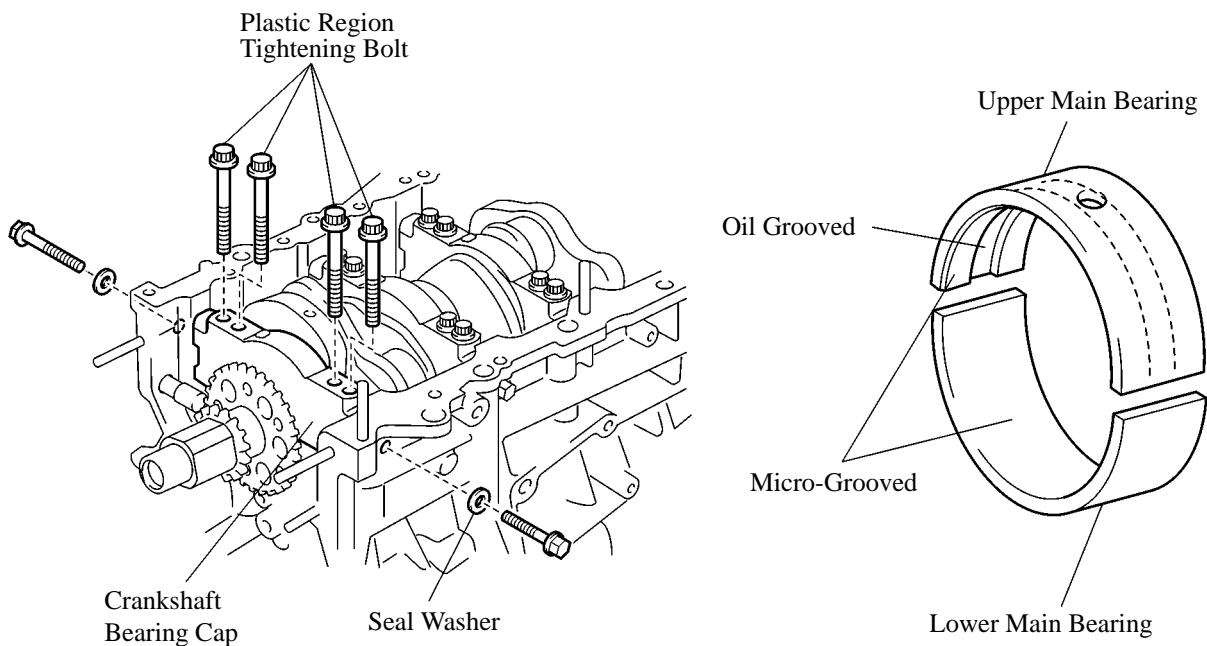

9. Crankshaft Pulley

The rigidity of the torsional damper rubber has been optimized to reduce noise.

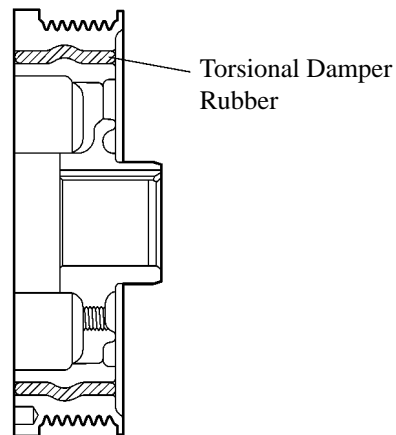

238EG18



10. Oil Pan

- The oil pan No.1 material is made of aluminum alloy.
- The oil pan No.2 material is made of steel.
- An oil passage has been integrated in the oil pan No.1 to simplify the construction of the oil strainer.
- The oil pan No.1 is secured to the cylinder block and the torque converter housing and is increasing rigidity.

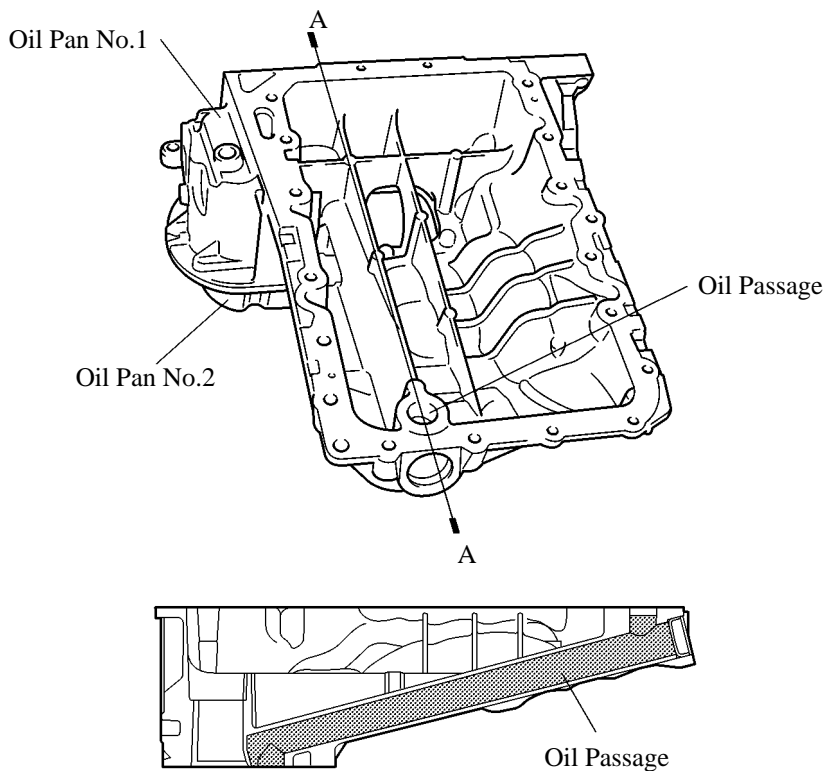

A – A Cross Section

238EG19