

## 5. Main Components of Engine Control System

### General

The main components of the 1GR-FE engine control system are as follows:

Component	Outline	Quantity
ECM	32-bit CPU	1
Air Fuel Ratio Sensor (Bank 1, Sensor 1) (Bank 2, Sensor 1)	with Heater Type (Planar Type)	2
Oxygen Sensor (Bank 1, Sensor 2) (Bank 2, Sensor 2)	with Heater Type (Planar Type)	2
Mass Air Flow Meter	Hot-wire Type	1
Crankshaft Position Sensor (Rotor Teeth)	Pick-up Coil Type (36-2)	1
VVT Sensor LH, RH (Rotor Teeth)	Pick-up Coil Type (3)	2
Knock Sensor 1, 2	Built-in Piezoelectric Type (Flat Type)	2
Accelerator Pedal Position Sensor	No-contact Type (Mounted on Accelerator Pedal)	1
Throttle Position Sensor	No-contact Type	1
Injector	12-Hole Type	6

### ECM

The 32-bit CPU of the ECM has been adopted to increase the speed for processing the signals.

### Oxygen Sensor and Air Fuel Ratio Sensor

Both the oxygen sensor and the air-fuel ratio sensor are the planar type. Compared to the conventional type, the sensor and heater portions of the planar type are narrower overall. Because the heat of the heater acts directly on the alumina and zirconia (of the sensor portion) it accelerates the activation of the sensor.

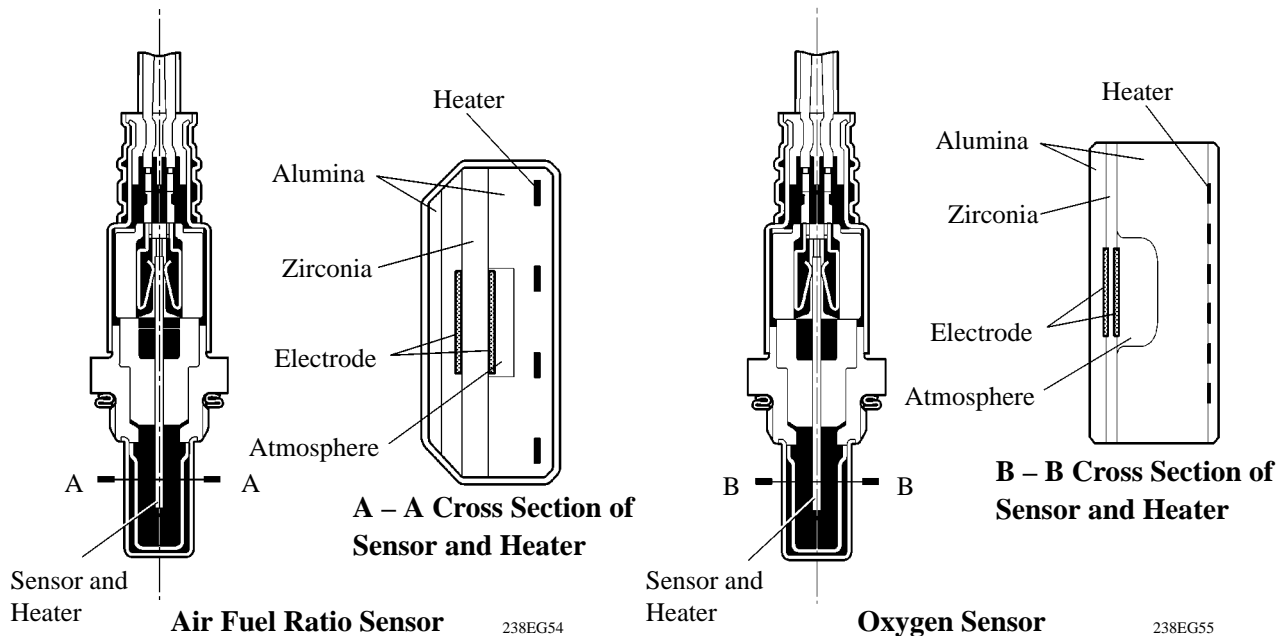

**Mass Air Flow Meter**

- This mass air flow meter, which is a plug-in type, allows a portion of the intake air to flow through the detection area. By directly measuring the mass and the flow rate of the intake air, the detection precision has been improved and the intake air resistance has been reduced.
- This mass air flow meter has a built-in intake air temperature sensor.

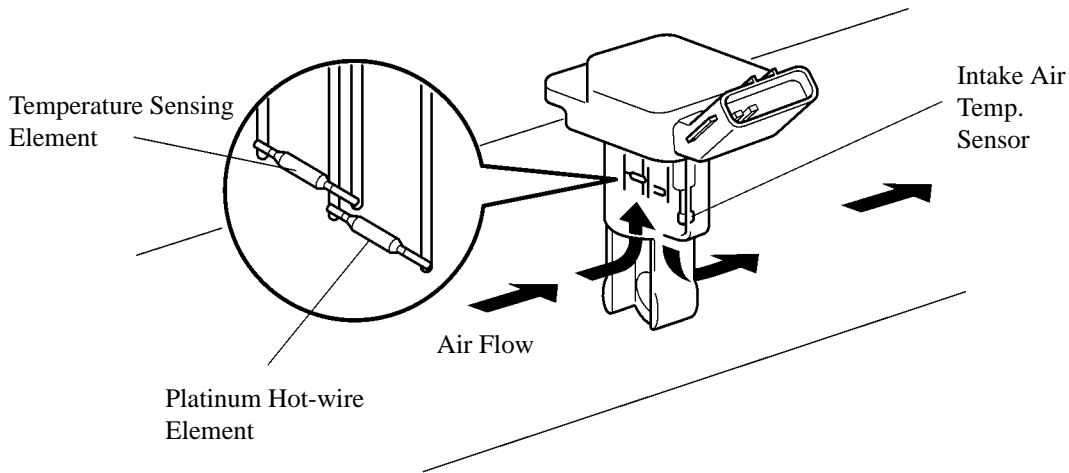

199EG35



**Crankshaft Position Sensor**

The timing rotor of the crankshaft consists of 34 teeth, with 2 teeth missing. The crankshaft position sensor outputs the crankshaft rotation signals every 10°, and the missing teeth are used to determine the top-dead-center.

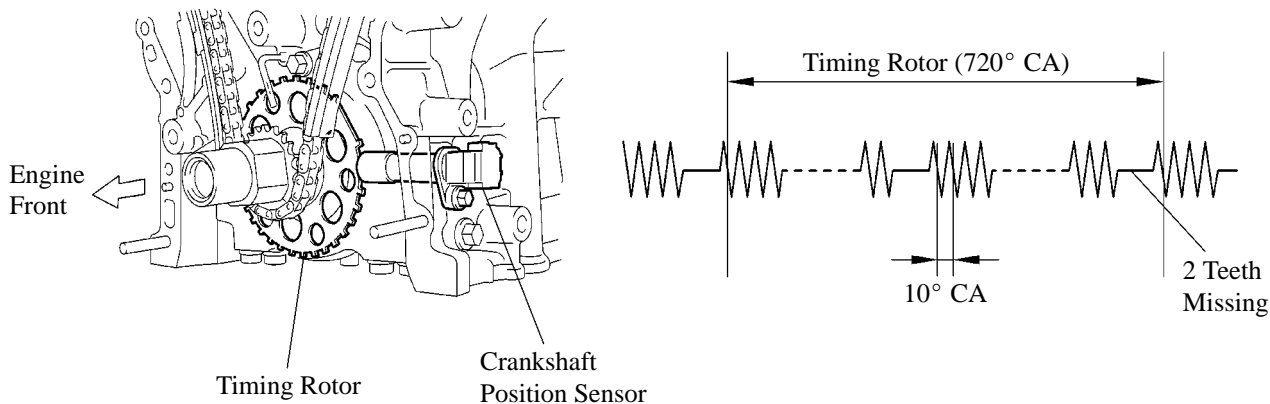

238EG56

**VVT Sensor**

The VVT sensors are mounted on the right and left banks of the cylinder heads. To detect the camshaft position, these sensors pick up the protrusion of the timing rotor that is secured to the camshaft in front of the VVT controller. In addition, each sensor generates 3 pulses for every 2 revolutions of the crankshaft.

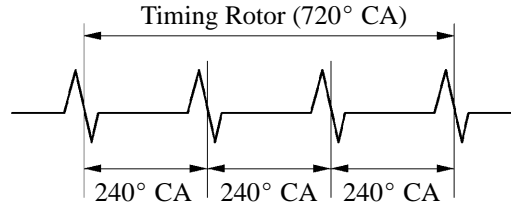
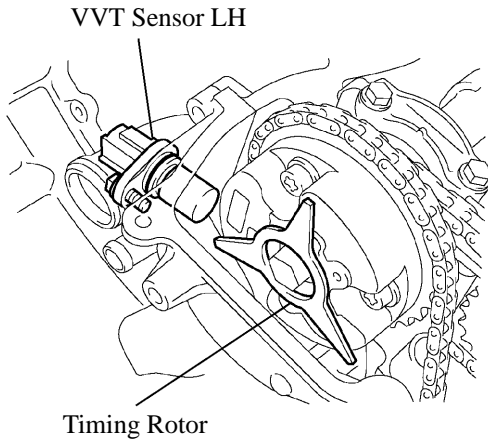

**Left Bank**

238EG57

**Knock Sensor (Flat Type)**

**1) General**

In the conventional type knock sensor (resonant type), a vibration plate which has the same resonance point as the knocking frequency of the engine is built in and can detect the vibration in this frequency band.

On the other hand, a flat type knock sensor (non-resonant type) has the ability to detect vibration in a wider frequency band from about 6 kHz to 15 kHz, and has the following features.

- The engine knocking frequency will change a bit depending on the engine speed. The flat type knock sensor can detect the vibration even when the engine knocking frequency is changed. Thus the vibration detection ability is increased compared to the conventional type knock sensor, and a more precise ignition timing control is possible.

— · — : Resonance Characteristic of Conventional Type

———— : Resonance Characteristic of Flat Type

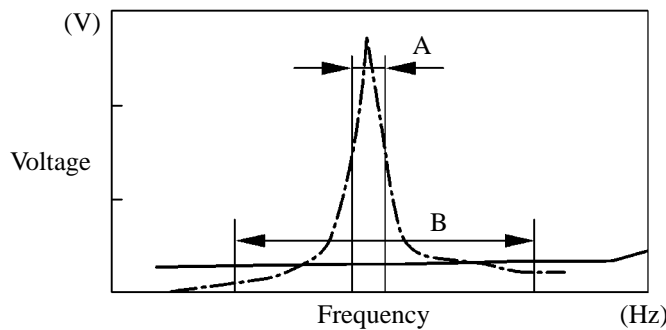

A: Detection Band of Conventional Type  
 B: Detection Band of Flat Type

**Characteristic of Knock Sensor**

214CE04

2) Construction

- The flat type knock sensor is installed on the engine through the stud bolt installed on the cylinder block. For this reason, a hole for the stud bolt is running through in the center of the sensor.
- Inside of the sensor, a steel weight is located on the upper portion and a piezoelectric element is located under the weight through the insulator.
- The open/short circuit detection resistor is integrated.

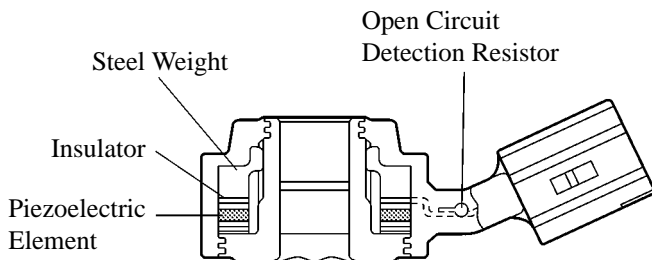

**Flat Type Knock Sensor  
(Non-Resonant Type)**

214CE01

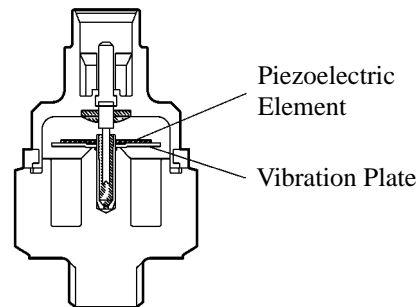

**Conventional Type Knock Sensor  
(Resonant Type)**

214CE02

NF

3) Operation

The knocking vibration is transmitted to the steel weight and its inertia applies pressure to the piezoelectric element. The action generates electromotive force.

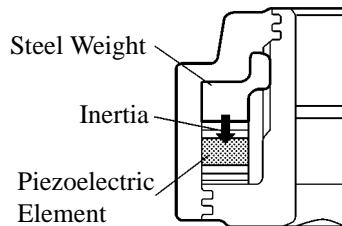

214CE08

#### 4) Open/Short Circuit Detection Resistor

During the ignition is ON, the open/short circuit detection resistor in the knock sensor and the resistor in the ECM keep the voltage at the terminal KNK1 of engine constant.

An IC (Integrated Circuit) in the ECM is always monitoring the voltage of the terminal KNK1. If the open/short circuit occurs between the knock sensor and the ECM, the voltage of the terminal KNK1 will change and the ECM detects the open/short circuit and stores DTC (Diagnostic Trouble Code).

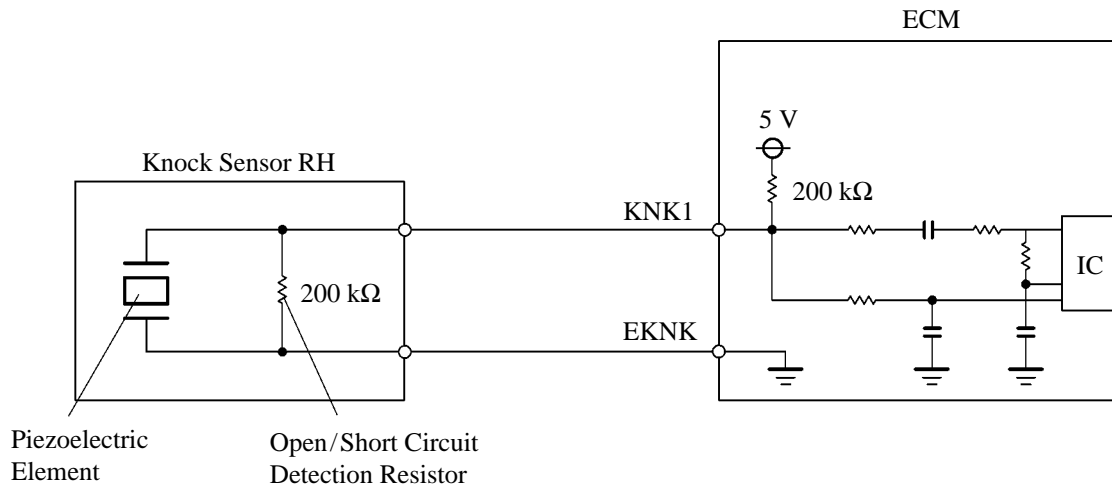

214CE06

#### Service Tip

- In accordance with the adoption of open/short circuit detection resistor, the inspection method for the sensor has been changed. For details, refer to 2003 4Runner Repair Manual Supplement (Pub. No. RM1034U).
- These knock sensors are mounted in the specific directions and angles as illustrated. To prevent the right and left bank connectors from being interchanged, make sure to install each sensor in its prescribed direction.

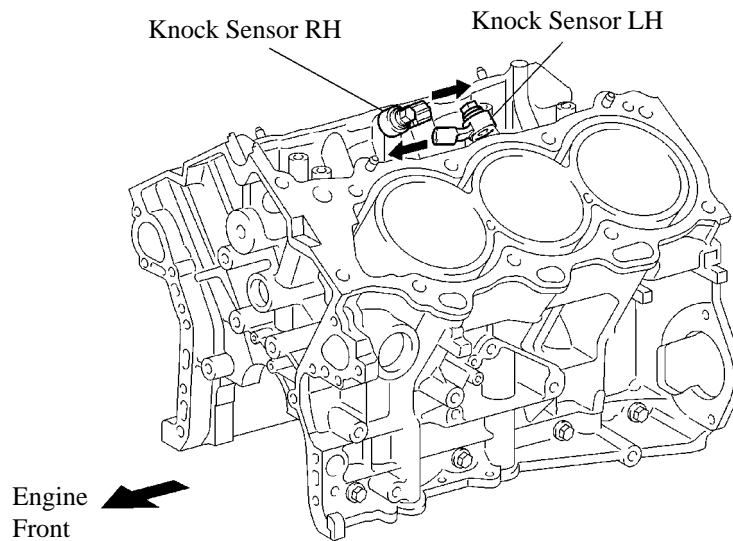

238EG58

**Accelerator Pedal Position Sensor**

The magnetic yoke that is mounted at the base of the accelerator pedal arm rotates around the Hall IC in accordance with the amount of effort that is applied to the accelerator pedal. The Hall IC converts the changes in the magnetic flux that occur at that time into electrical signals, and outputs them in the form of accelerator pedal effort to the ECM.

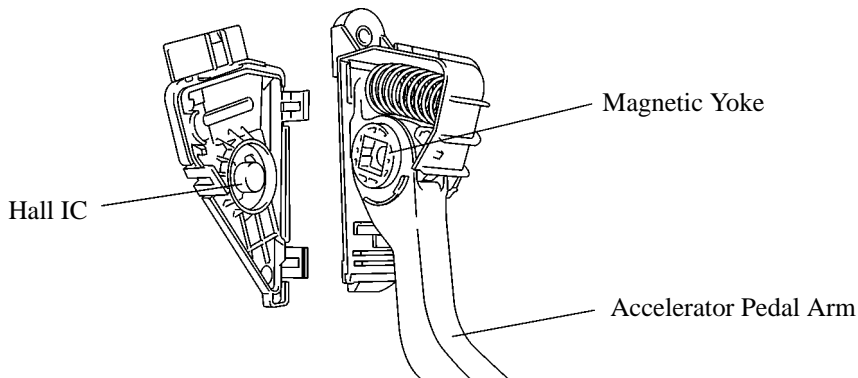

228TU23

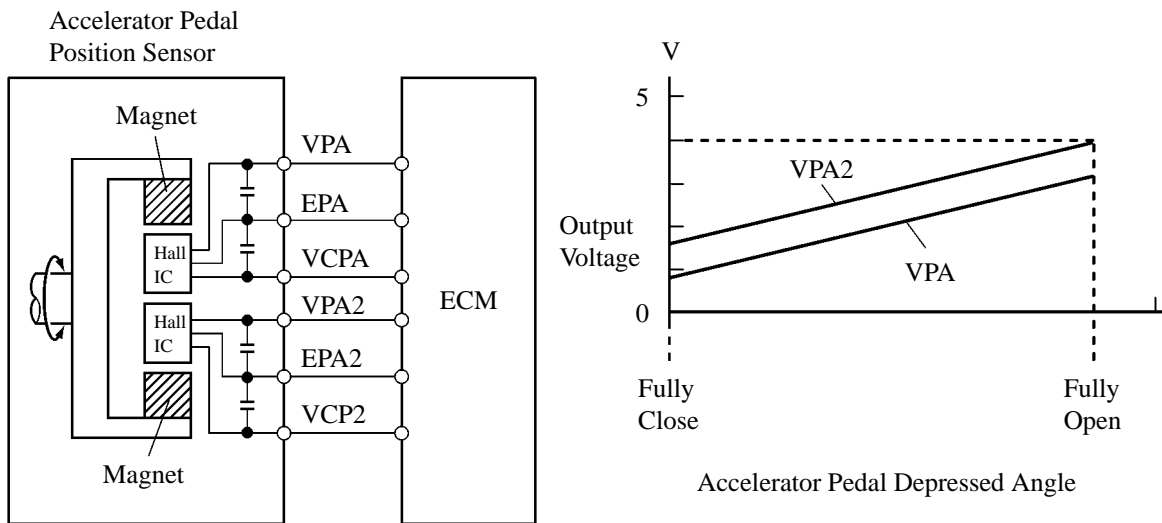

228TU24

228TU25

**Service Tip**

The inspection method differs from the conventional accelerator pedal position sensor because this sensor uses a hall IC. For details, refer to the 2003 4Runner Repair Manual Supplement (Pub. No. RM1034U.)

**Throttle Position Sensor**

The throttle position sensor is mounted on the throttle body, to detect the opening angle of the throttle valve, the throttle position sensor converts the magnetic flux density that changes when the magnetic yoke (located on the same axis as the throttle shaft) rotates around the Hall IC into electric signals to operate the throttle control motor.

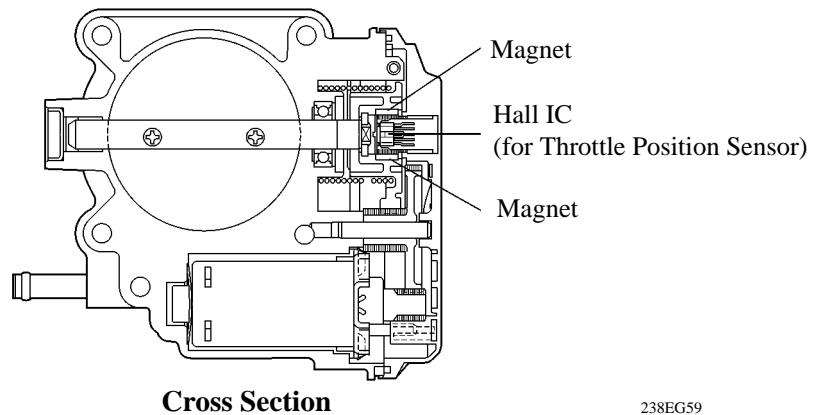
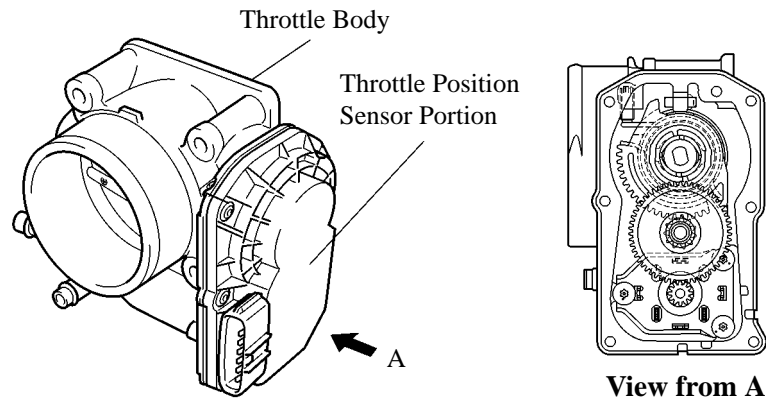

238EG59

Throttle Position Sensor

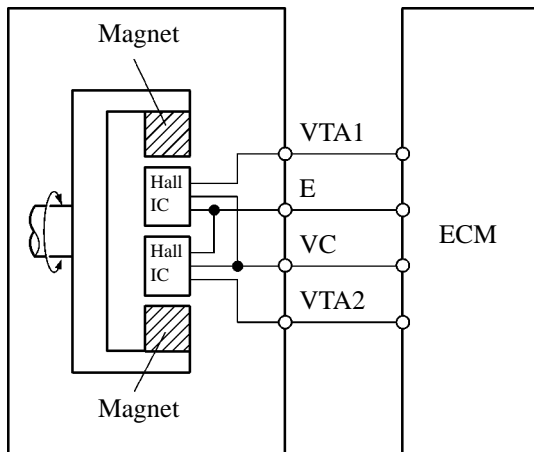

230LX12

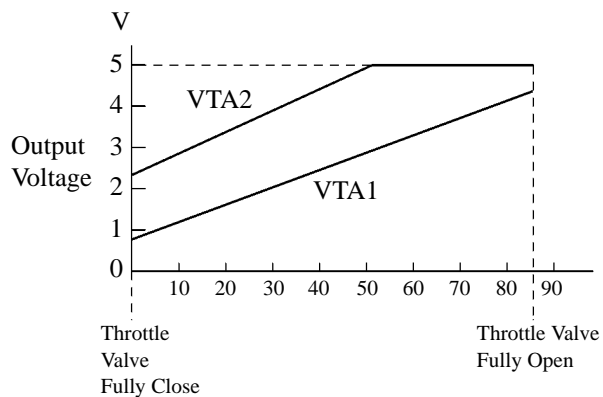

**Throttle Valve Opening Angle**

238EG79

**Service Tip**

The inspection method differs from the conventional throttle position sensor because this sensor uses a Hall IC. For details, refer to the 2003 4Runner Repair Manual Supplement (Pub. No. RM1034U.)

## 6. SFI (Sequential Multiport Fuel Injection) System

- An L-type SFI system directly detects the intake air mass with a hot wire type mass air flow meter.
- An independent injection system (in which fuel is injected once into each cylinder for each two revolution of the crankshaft) has been adopted.
- There are two types of fuel injection:
  - a) One is synchronous injection in which corrections based on the signals from the sensors are added to the basic injection duration so that injection occurs always at the same timing.
  - b) The other is non-synchronous injection in which injection is effected by detecting the requests from the signals of the sensors regardless of the crankshaft angle.

Furthermore, to protect the engine and improve fuel economy, the system effects fuel cutoff in which the injection of fuel is stopped temporarily in accordance with the driving conditions.

- This system performs group injection when the engine coolant temperature is extremely low and the engine is operating at a low speed.

