

NEW FEATURES

1GR-FE ENGINE

■ DESCRIPTION

- The 1GR-FE engine on the '03 4Runner is a newly developed V6, 4.0-liter, 24-valve DOHC engine. This engine has adopted the VVT-i (Variable Valve Timing-intelligent) system, ACIS (Acoustic Control Induction System), and ETCS-i (Electronic Throttle Control System-intelligent). These control functions have been optimized to further improve engine performance, fuel economy, and reduce exhaust emissions.
- This engine has been made compact and lightweight through the adoption of an aluminum cylinder block and plastic intake air chamber, fuel delivery pipe, and water inlet pipe.

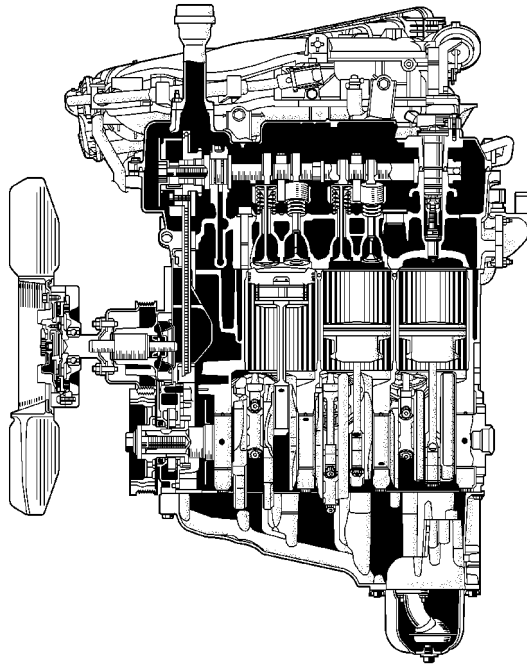

238EG01

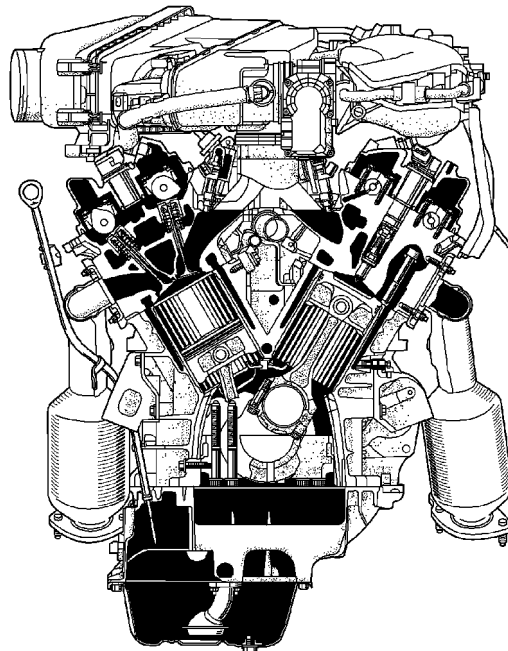

238EG02

► Engine Specifications ◀

Engine Type		1GR-FE	
No. of Cyls. & Arrangement		6-Cylinder, V Type	
Valve Mechanism		24-Valve DOHC, Chain Drive (with VVT-i)	
Combustion Chamber		Pentroof Type	
Manifolds		Cross-Flow	
Fuel System		SFI	
Ignition System		DIS	
Displacement	cm ³ (cu.in.)	3956 (241.4)	
Bore x Stroke	mm (in.)	94.0 x 95.0 (3.70 x 3.74)	
Compression Ratio		10.0 : 1	
Max. Output	(SAE-NET)	183 kW @5200 rpm (245 HP @5200 rpm)	
Max. Torque	(SAE-NET)	382 N·m @3800 rpm (282 ft·lbf @3800 rpm)	
Valve Timing	Intake	Open	-8 ~ 42° BTDC
		Close	60° ~ 10° ABDC
	Exhaust	Open	54° BBDC
		Close	2° ATDC
Firing Order		1 - 2 - 3 - 4 - 5 - 6	
Research Octane Number		96 or more	
Octane Rating		91 or more	
Engine Service Mass* (Reference)	kg (lb)	Approx. 166 (366)	
Oil Grade		API SL, EC or ILSAC	
Tailpipe Emission Regulation		LEV, NLEV, SFTP	
Evaporative Emission Regulation		LEV-II, ORVR	

NF

*: Weight shows the figure with the oil and engine coolant fully filled.

► Performance Curve ◀

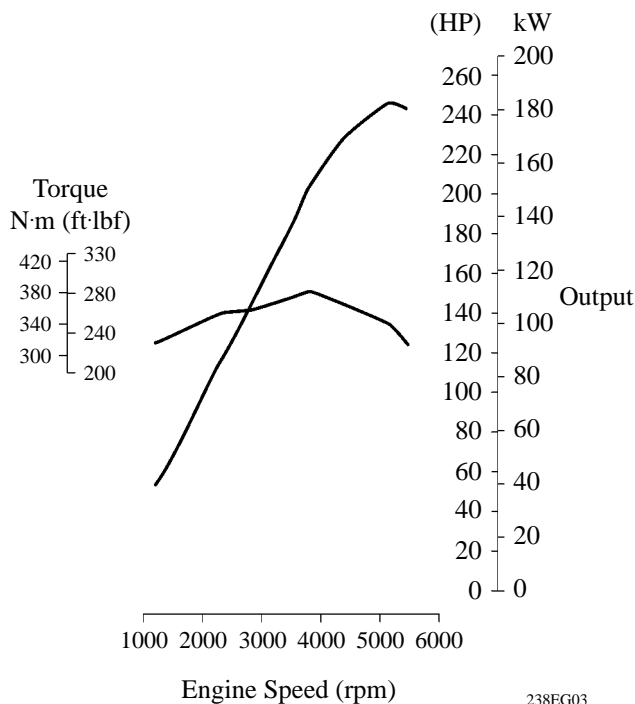

► Valve Timing ◀

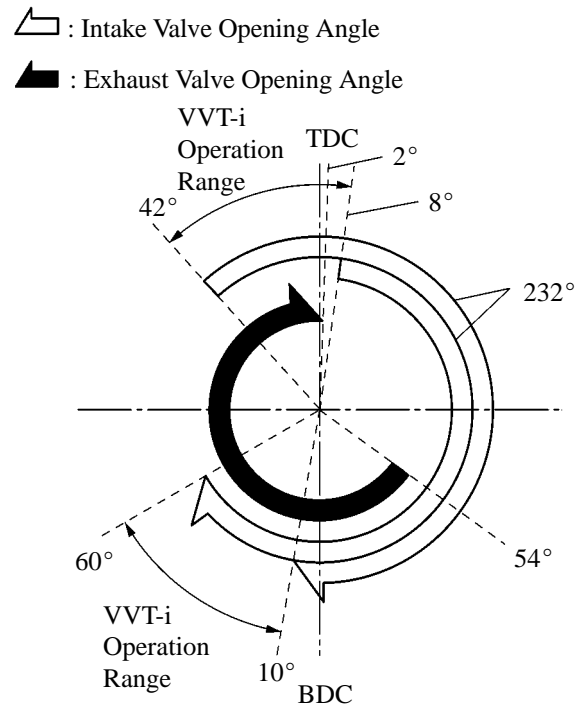

■ FEATURES OF 1GR-FE ENGINE

The 1GR-FE engine has been able to achieve the following performance through the adoption of the items listed below.

- (1) High performance and reliability
- (2) Low noise and vibration
- (3) Lightweight and compact design
- (4) Good serviceability
- (5) Clean emission and fuel economy

Item		(1)	(2)	(3)	(4)	(5)
Engine Proper	An upright intake port is used.	○		○		
	A taper squish shape is used for combustion chamber.	○				○
	A steel laminate type cylinder head gasket is used.	○				
	A cylinder block made of aluminum alloy is used			○		
	An oil pan No.1 made of aluminum alloy is used.		○	○		
	The skirt portion of the piston is applied with resin plating to reduce friction.	○	○			○
	The water inlet pipe made of plastic is used.			○		
Valve Mechanism	A shim-less type valve lifters are used.	○		○		
	The VVT-i system is used.	○				○
Intake and Exhaust System	The intake air chamber made of plastic is used.			○		
	The link-less type throttle body has been adopted.			○	○	
Fuel System	12-hole type fuel injectors are used to improve the atomization of fuel.	○				○
	The fuel delivery pipe made of plastic is used.			○		
Ignition System	The long-reach type spark plugs have been adopted.	○				
Charging and Starting System	Segment Conductor type generator is used.	○		○		
	PS (Planetary reduction-Segment conductor motor) type starter is used.	○		○		
Engine Control System	The ETCS-i is used.	○				○
	The ACIS is used.	○				○
	The DIS (Direct Ignition System) makes ignition timing adjustment unnecessary.	○			○	○
	Cranking hold function has been adopted.	○				
	The no-contact sensor has been adopted in the throttle position sensor.	○				
	The no-contact sensor has been adopted in the accelerator pedal position sensor.	○				
	The planar type air fuel ratio sensor and oxygen sensor have been adopted.					○
Evaporative Emission System	A carbon filter, which adsorbs the HC that accumulates in the intake system when the engine is stopped, has been adopted in the air cleaner cap.					○
	A service port has been provided for inspecting the evaporating emission control system.				○	
	The vacuum type monitor has been adopted to detect leaks in the evaporative emission control system.				○	○