

### 8. VVT-i (Variable Valve Timing-intelligent) System

#### General

- The VVT-i system is designed to control the intake camshaft within a range of 50° (of Crankshaft Angle) to provide valve timing that is optimally suited to the engine condition. This improves torque in all the speed ranges as well as increasing fuel economy, and reducing exhaust emissions.

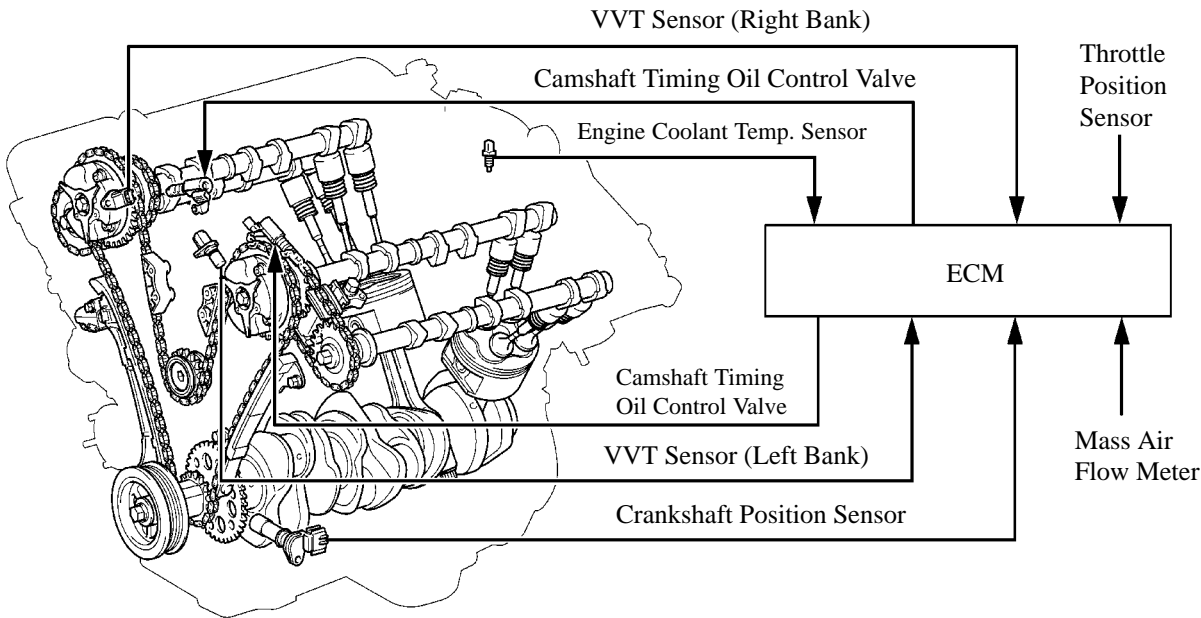

238EG60

- Using the engine speed, intake air volume, throttle position and engine coolant temperature, the ECM can calculate optimal valve timing for each driving condition and controls the camshaft timing oil control valve. In addition, the ECM uses signals from the camshaft position sensor and the crankshaft position sensor to detect the actual valve timing, thus providing feedback control to achieve the target valve timing.

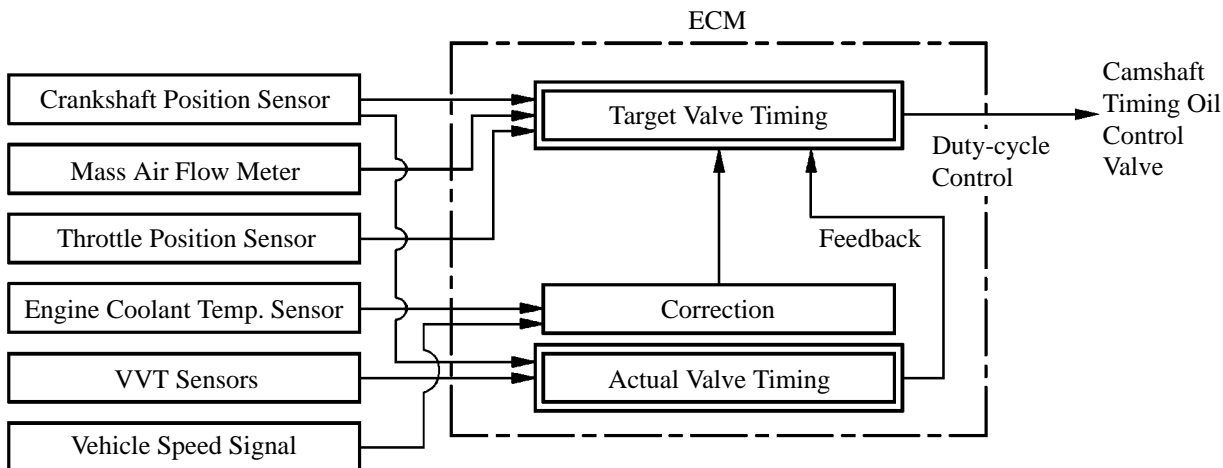

221EG16

**Effectiveness of the VVT-i System**

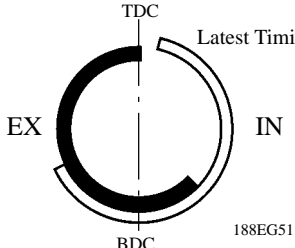
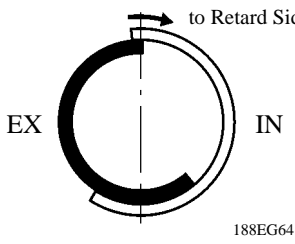
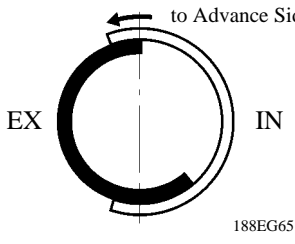
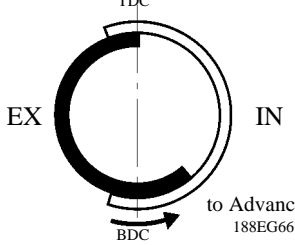
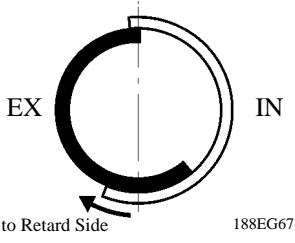
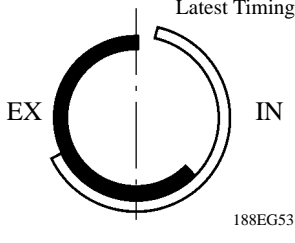
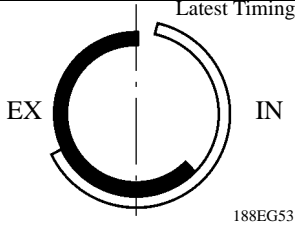
| Operation State  | Objective  | Effect   |
|--|--|--|
| <p>During Idling</p>   |  <p>Eliminating overlap to reduce blow back to the intake side</p>  | <ul style="list-style-type: none"> <li>● Stabilized idling rpm</li> <li>● Better fuel economy</li> </ul>     |
| <p>At Light Load</p>   |  <p>Decreasing overlap to eliminate blow back to the intake side.</p>   | <p>Ensured engine stability</p>  |
| <p>At Medium Load</p>  |  <p>Increasing overlap to increase internal EGR to reduce pumping loss</p>  | <ul style="list-style-type: none"> <li>● Better fuel economy</li> <li>● Improved emission control</li> </ul> |
| <p>In Low to Medium Speed Range with Heavy Load</p>  |  <p>Advancing the intake valve close timing for volumetric efficiency improvement</p>  | <p>Improved torque in low to medium speed range</p>  |
| <p>In High Speed Range with Heavy Load</p>   |  <p>Retarding the intake valve close timing for volumetric efficiency improvement</p>   | <p>Improved output</p>   |
| <p>At Low Temperatures</p>   |  <p>Eliminating overlap to prevent blow back to the intake side leads to the lean burning condition, and stabilizes the idling speed at fast idle</p> | <ul style="list-style-type: none"> <li>● Stabilized fast idle rpm</li> <li>● Better fuel economy</li> </ul>  |
| <ul style="list-style-type: none"> <li>● Upon Starting</li> <li>● Stopping the Engine</li> </ul> |  <p>Eliminating overlap to minimize blow back to the intake side</p>  | <p>Improved startability</p>   |

**Construction**

**1) VVT-i Controller**

This controller consists of the housing driven from the timing chain and the vane coupled with the intake camshaft.

The oil pressure sent from the advance or retard side path at the intake camshaft causes rotation in the VVT-i controller vane circumferential direction to vary the intake valve timing continuously.

When the engine is stopped, the intake camshaft will be in the most retarded state to ensure startability.

When hydraulic pressure is not applied to the VVT-i controller immediately after the engine has been started, the lock pin locks the movement of the VVT-i controller to prevent a knocking noise.

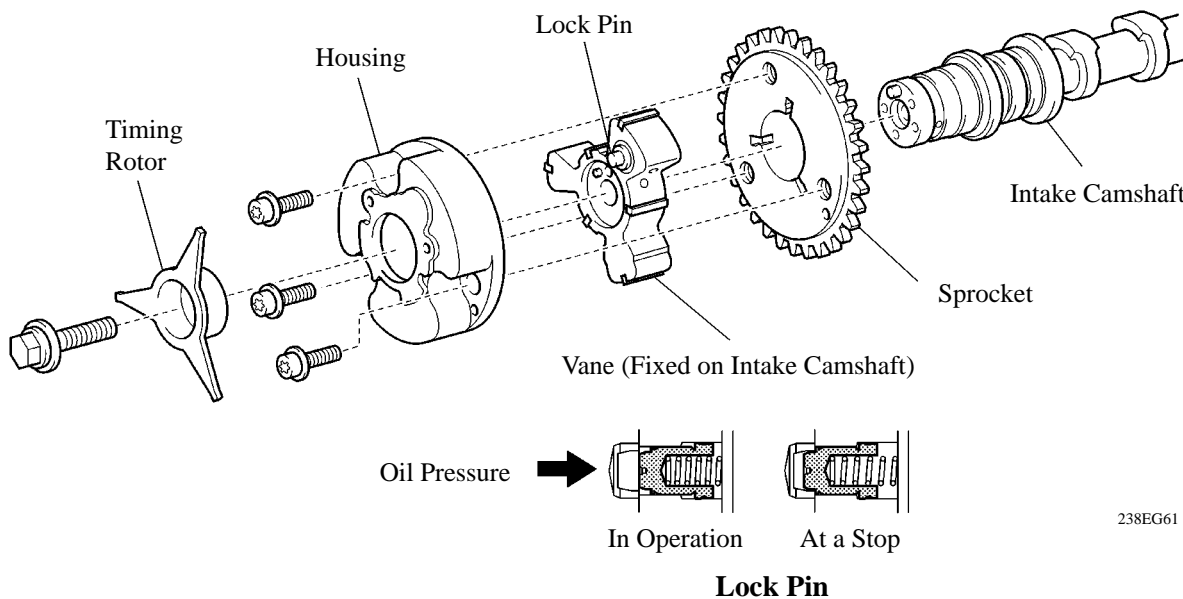

238EG61

**2) Camshaft Timing Oil Control Valve**

This camshaft timing oil control valve controls the spool valve position in accordance with the duty-cycle control from the ECM. This allows hydraulic pressure to be applied to the VVT-i controller advance or retard side. When the engine is stopped, the camshaft timing oil control valve is in the most retarded state.

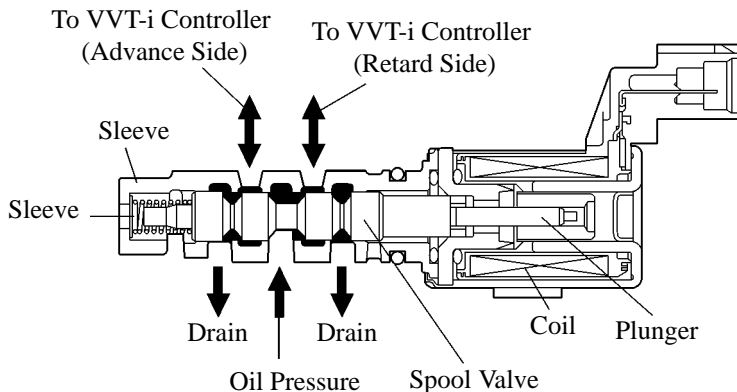

238EG62

## Operation

### 1) Advance

When the camshaft timing oil control valve is positioned as illustrated below by the advance signals from the ECM, the resultant oil pressure is applied to the vane chamber of advance side to rotate the camshaft in the timing advance direction.

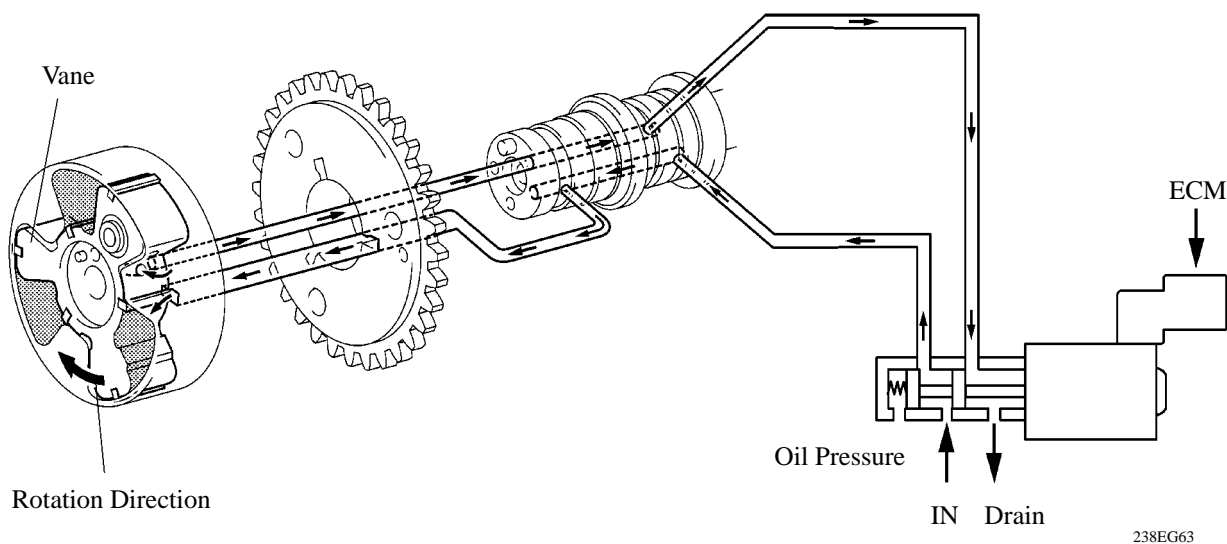

### 2) Retard

When the camshaft timing oil control valve is positioned as illustrated below by the retard signals from the ECM, the resultant oil pressure is applied to the vane chamber of retard side to rotate the camshaft in the timing retard direction.

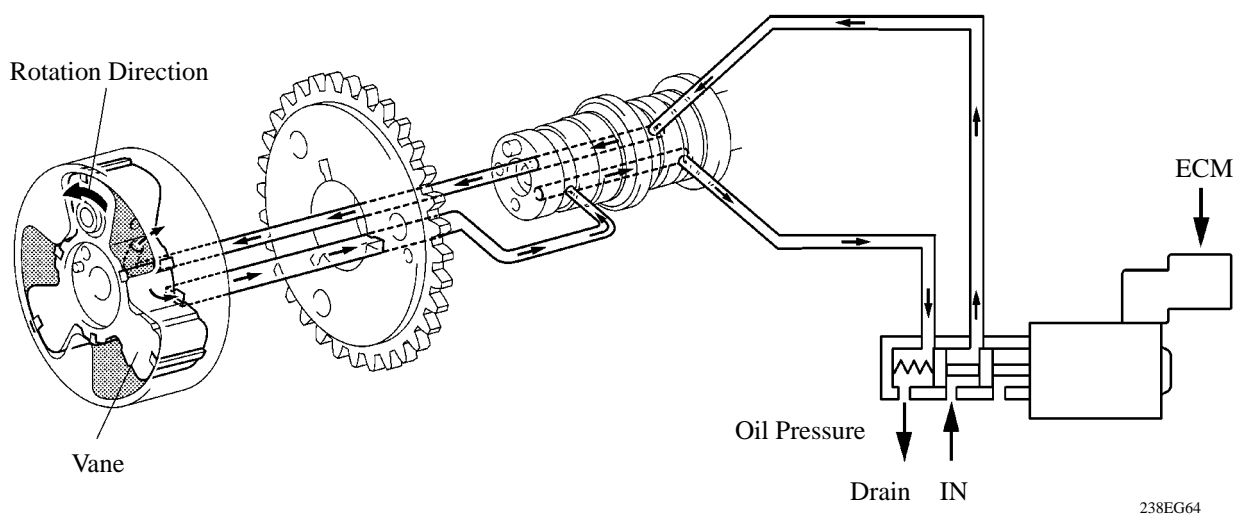

### 3) Hold

After reaching the target timing, the valve timing is held by keeping the camshaft timing oil control valve in the neutral position unless the traveling state changes.

This adjusts the valve timing at the desired target position and prevents the engine oil from running out when it is unnecessary.