

■ CHARGING SYSTEM

Generator

General

A compact and lightweight Segment Conductor type generator that generates high amperage output in a highly efficient manner has been adopted.

► Component of Segment Conductor Type Generator ◀

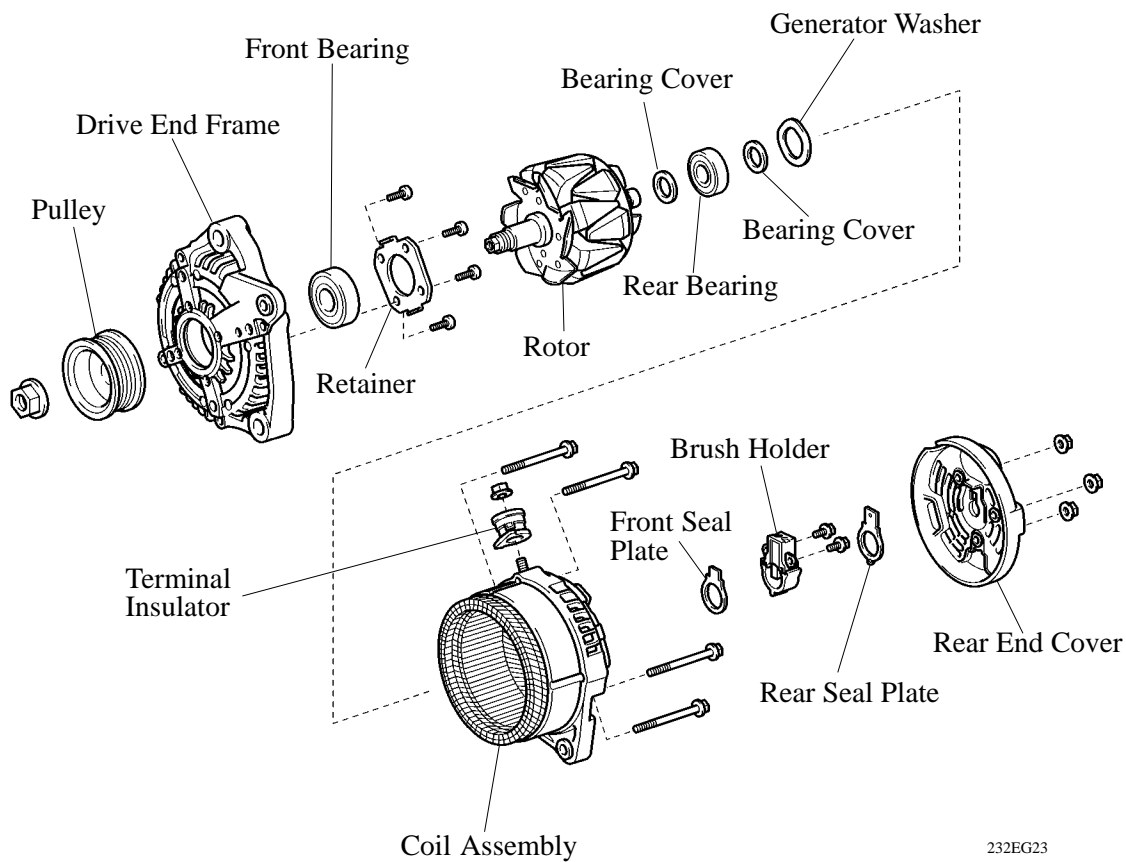

232EG23

Service Tip

Although the charging circuit of a conventional generator is checked through the F terminal, this check cannot be performed on the Segment Conductor type generator through the use of the F terminal because the F terminal has been eliminated.

For details, refer to see the 2003 4Runner Repair Manual (Pub. No. RM1001U).

► Wiring Diagram ◀

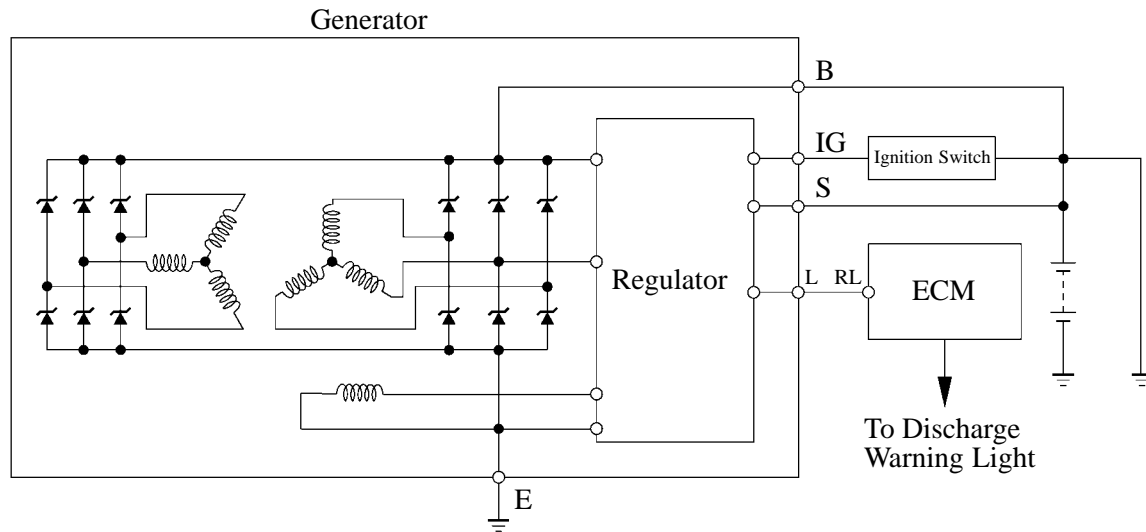

198EG16

Construction and Operation

- This generator uses a joined segment conductor system, in which multiple segment conductors are welded together to form the stator. Compared to the conventional winding system, the electrical resistance is reduced due to the shape of the segment conductors, and their arrangement helps to make the generator more compact.

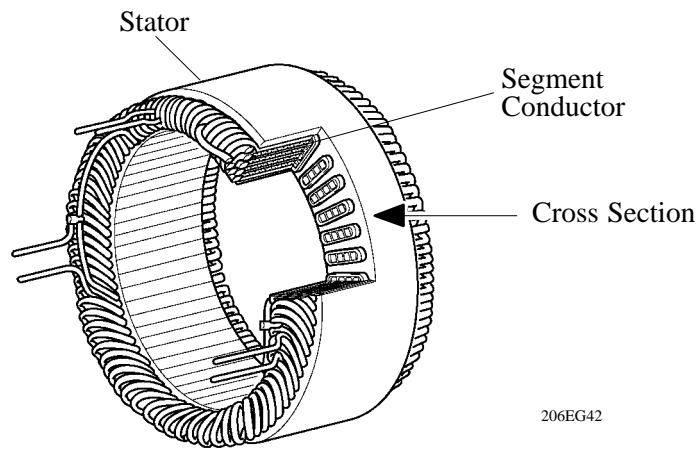
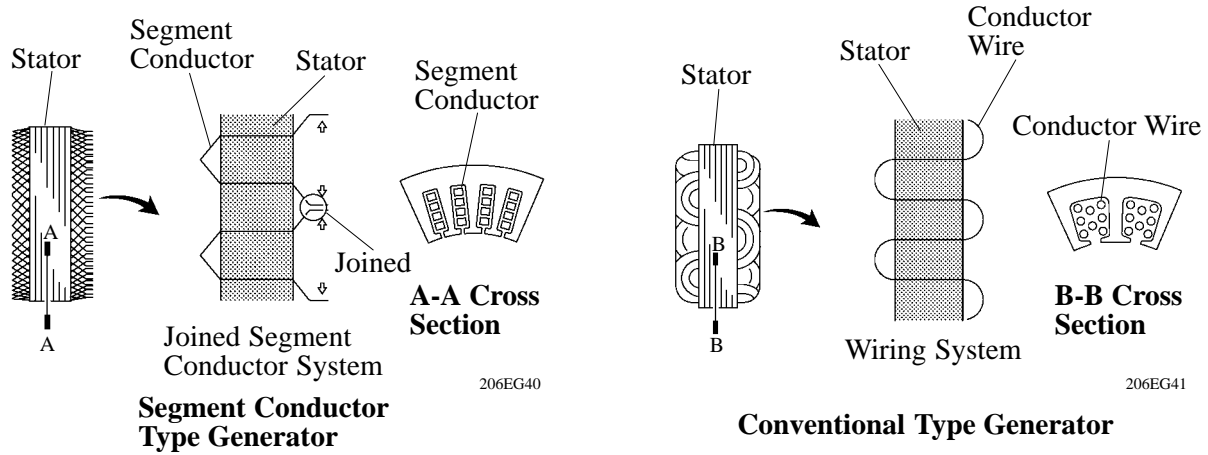

Stator of Segment Conductor Type Generator

- A dual winding system has been adopted. This system consists of two sets of three-phase windings whose phases are staggered 30°. Because the magnetic fluctuations of the respective windings cancel each other out, magnetic noise, radio frequency interference is reduced.

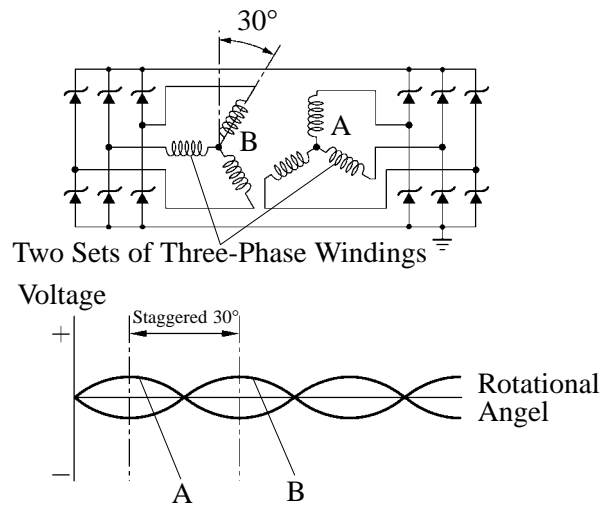

198EG14

Segment Conductor Type Generator

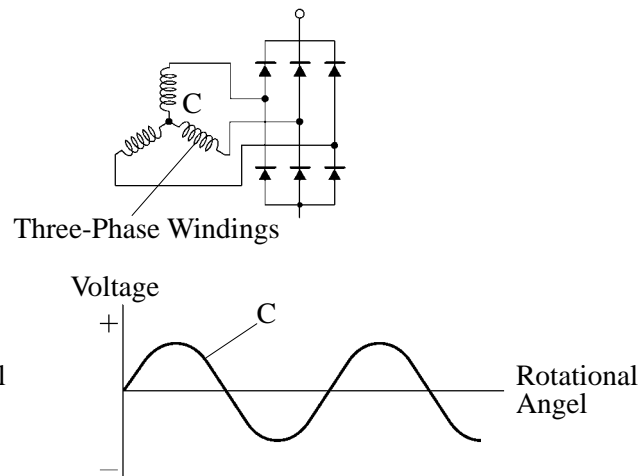

198EG15

Conventional Type Generator