

■ ENGINE PROPER

1. Cylinder Head Cover

- Lightweight yet high-strength aluminum head covers are used.
- An adapter has been provided on the left bank cylinder head cover to improve the serviceability when filling the engine oil.
- The cylinder head cover gaskets are used a double-bead cross-sectional construction to improve their reliability.

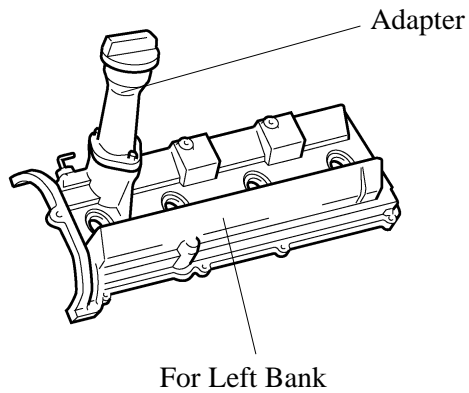

196EG01

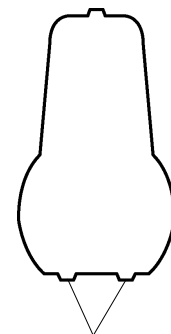

Double-Bead  
Cylinder Head Cover  
Gasket Cross Section

232EG16

2. Cylinder Head Gasket

3-layer cylinder head gaskets with shims are used to ensure reliability and to minimize the deformation of the cylinder bore. This resulted in improved fuel economy and reduced the consumption rate of engine oil and the emission of exhaust gases.

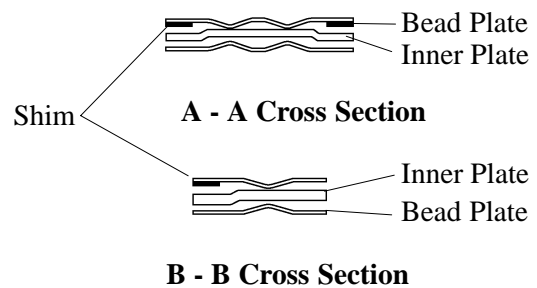
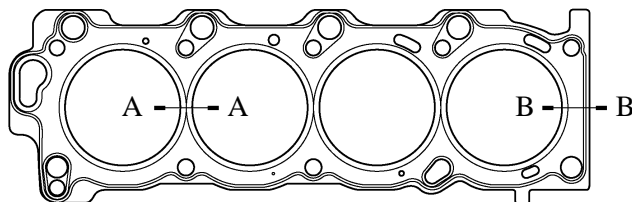

156EG33

### 3. Cylinder Head

- The cylinder head, which is made of aluminum, is used a pentroof-type combustion chamber. The spark plug has been located in the center of the combustion chamber in order to improve the engine's anti-knocking performance.
- The angle of the intake and exhaust valves is narrowed and set at  $21.55^\circ$  to permit a compact cylinder head.
- Upright intake ports are used to improve the intake efficiency.
- A taper squish combustion chamber is used to improve anti-knocking performance and intake efficiency. In addition, engine performance and fuel economy have been improved.
- Plastic region tightening bolts are used for the cylinder head for good axial tension.

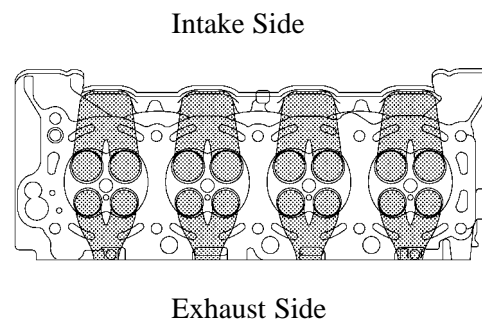
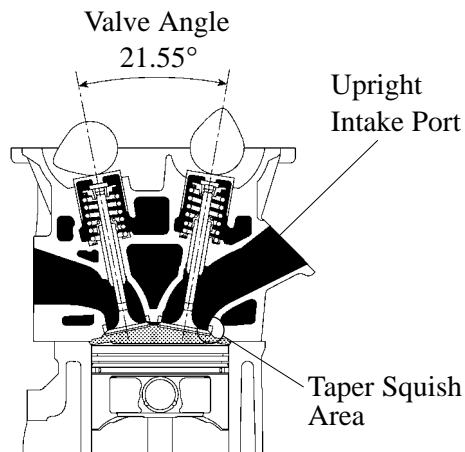

### 4. Cylinder Block

- The cylinder block is made of cast iron.
- The cylinder block has a bank angle of  $90^\circ$ , a bank offset of 21 mm (0.827 in.) and a bore pitch of 105.5 mm (4.15 in.), resulting in a compact block in its length and width even for its displacement.
- Part of the volute chamber of the water pump is incorporated into the cylinder block to shorten the engine length.
- Installation bosses for the two knock sensors are located on the inner side of left and right banks.
- Plastic region tightening bolts are used for the crankshaft bearing caps.
- The starter is located inside the V-bank.

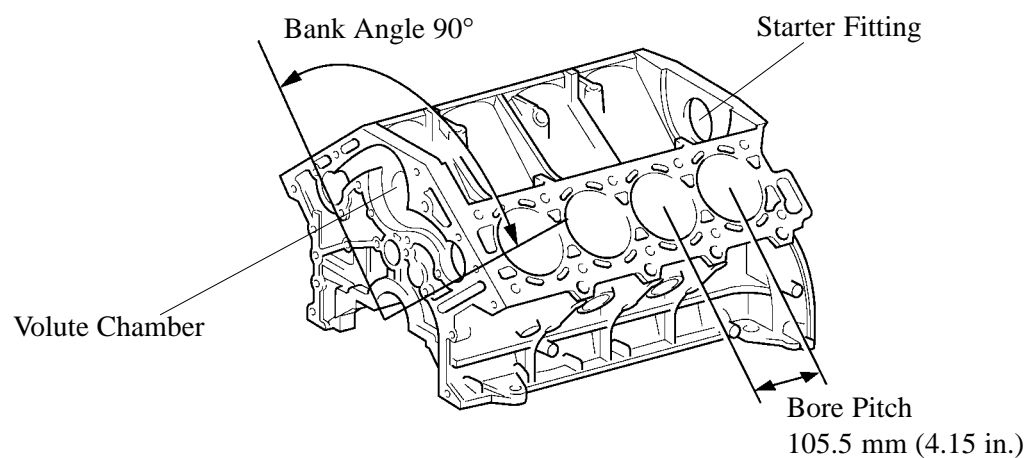

## 5. Piston

- The piston is made of aluminum alloy.
- The piston head portion has adopted a taper squish to improve the fuel combustion efficiency.
- The piston ring grooves have been treated with anodic treatment to improve the piston's wear resistance.
- Full floating type piston pins are used.
- The skirt portion of the piston has been applied with resin coating to reduce friction.

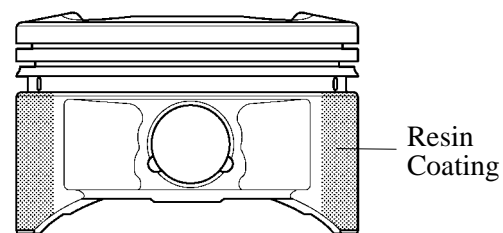

156EG02

## 6. Connecting Rod

- The sintered and forged connecting rod is very rigid and has little weight fluctuation.
- A weight-adjusting boss is provided at the big end to reduce fluctuation of weight and balance the engine assembly.
- The connecting rod cap is held by plastic region tightening bolts.
- The connecting rods for the right and left banks are placed in opposite directions with the outer marks facing the crankshaft.
- The connecting rod bearing is made of aluminum alloy.

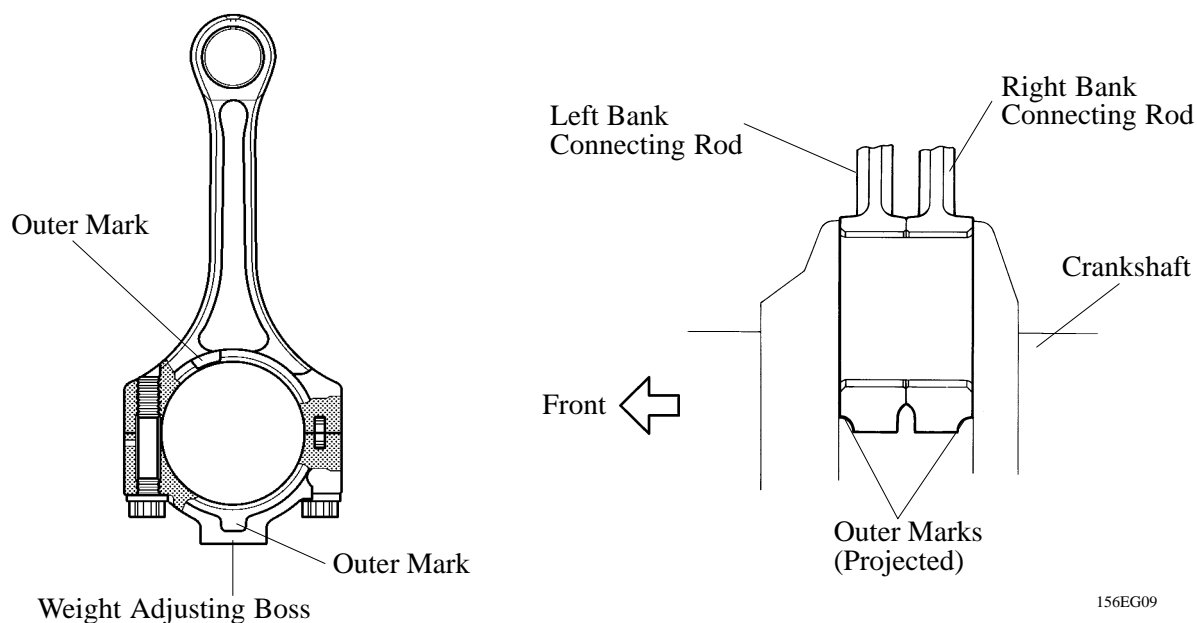

156EG03

156EG09

### 7. Crankshaft

- A crankshaft made of steel, which excels, in rigidity and wear resistance, is used.
- The crankshaft has 5 journals and 8 counter weights.
- The crankshaft bearing is made of aluminum alloy.

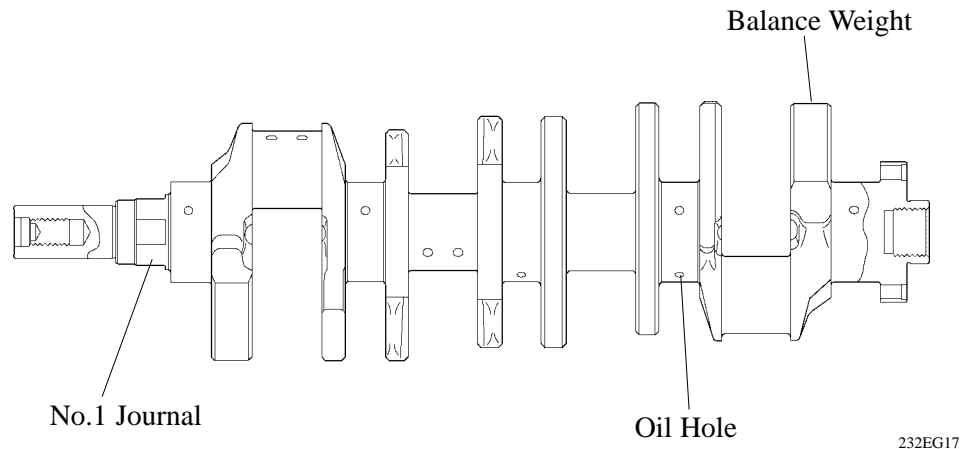

232EG17

**NOTE:** The positions of the crankshaft pins and pistons are illustrated below. The numbers of the crankshaft and the pistons are shown on the right.

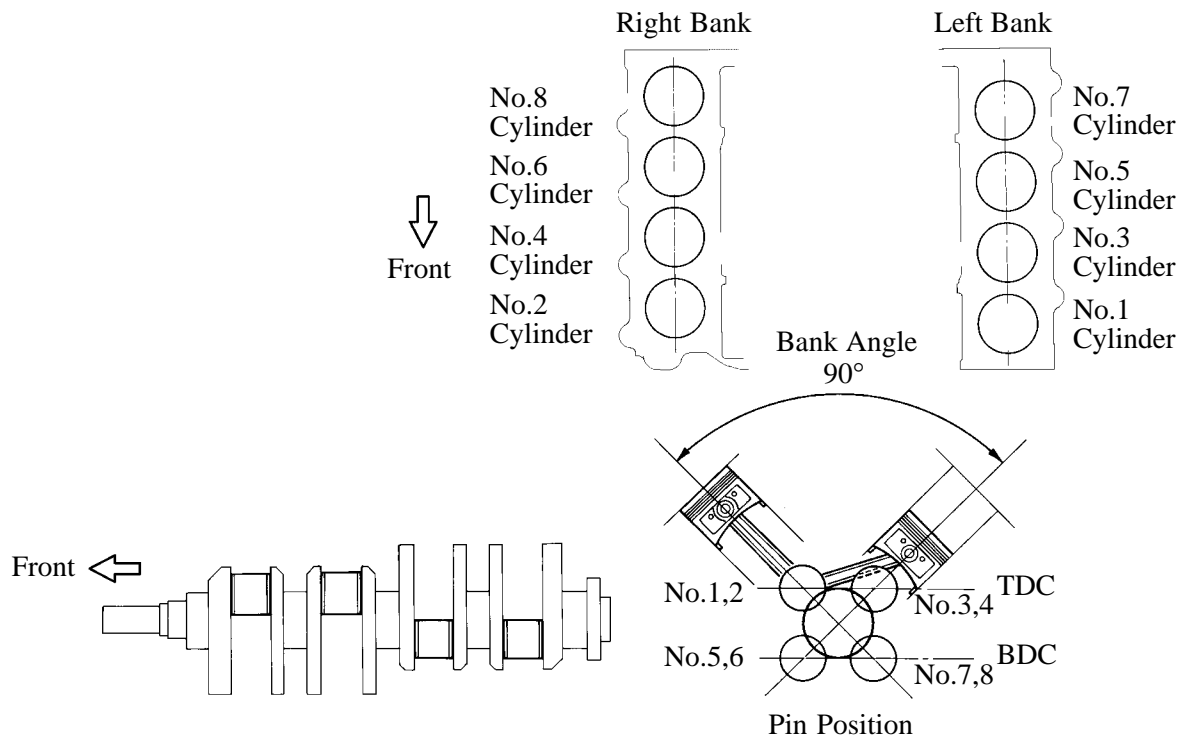

156EG10

- Crankshaft angles and engine strokes (intake, compression, combustion and exhaust) are shown in the table below. The firing order is 1 - 8 - 4 - 3 - 6 - 5 - 7 - 2.

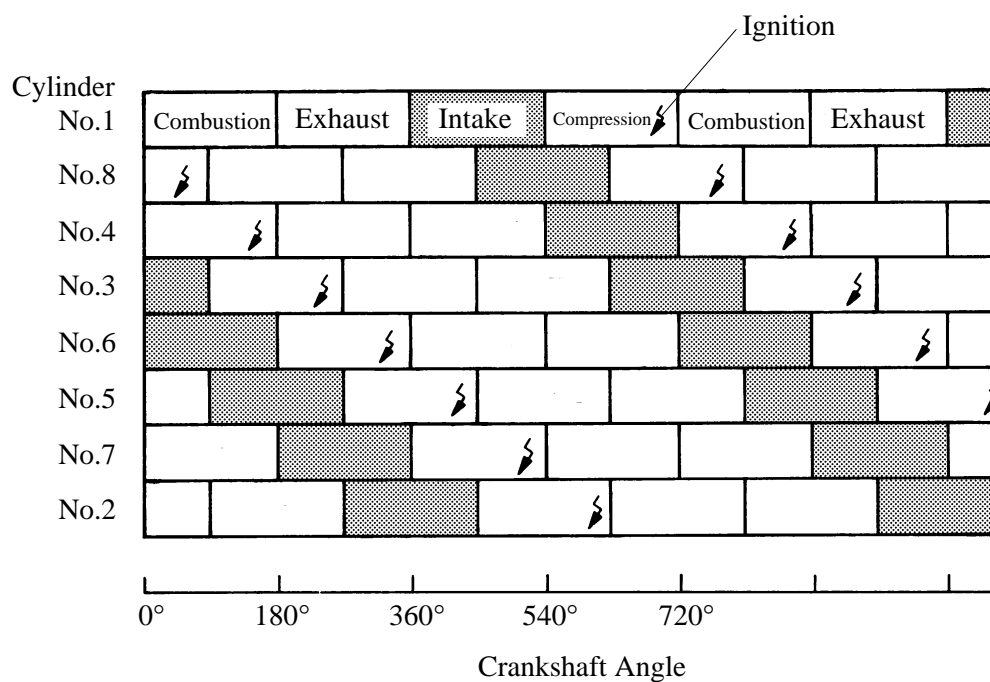

156EG11

### 8. Crankshaft Pulley

The rigidity of the torsional damper rubber has been optimized to reduce noise.

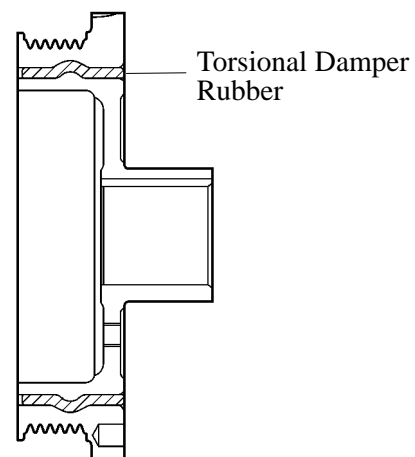

232EG26