

## ■ IGNITION SYSTEM

### 1. General

A DIS (Direct Ignition System) is used in the 2UZ-FE engine. The DIS improves the ignition timing accuracy, reduces high-voltage loss, and enhances the overall reliability of the ignition system by eliminating the distributor.

The DIS in 2UZ-FE engine is an independent ignition system which has one ignition coil for each cylinder.

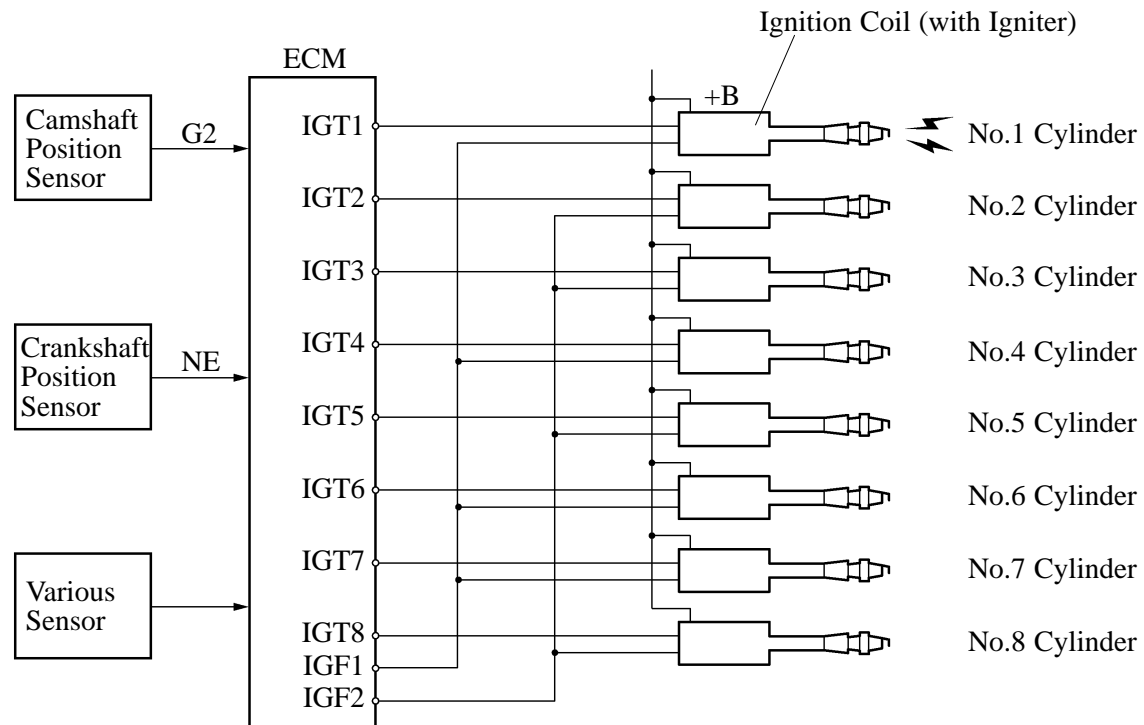

151EG05

### 2. Ignition Coil

The DIS provides 8 ignition coils, one for each cylinder. The spark plug caps, which provide contact to spark plugs, are integrated with an ignition coil. Also, an igniter is enclosed to simplify the system.

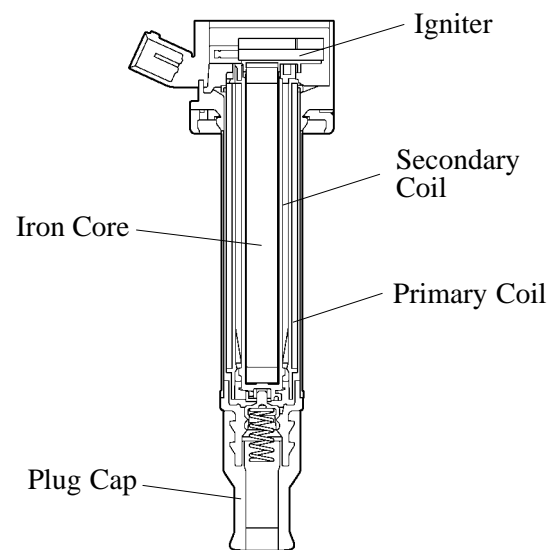

**Ignition Coil Cross Section**

156EG16