

■ LUBRICATION SYSTEM

1. General

- The lubrication circuit is fully pressurized and all oil passes through an oil filter.
- A trochoid gear type oil pump is directly driven by crankshaft.
- The water-cooled type engine oil cooler is used to lower the oil temperature.

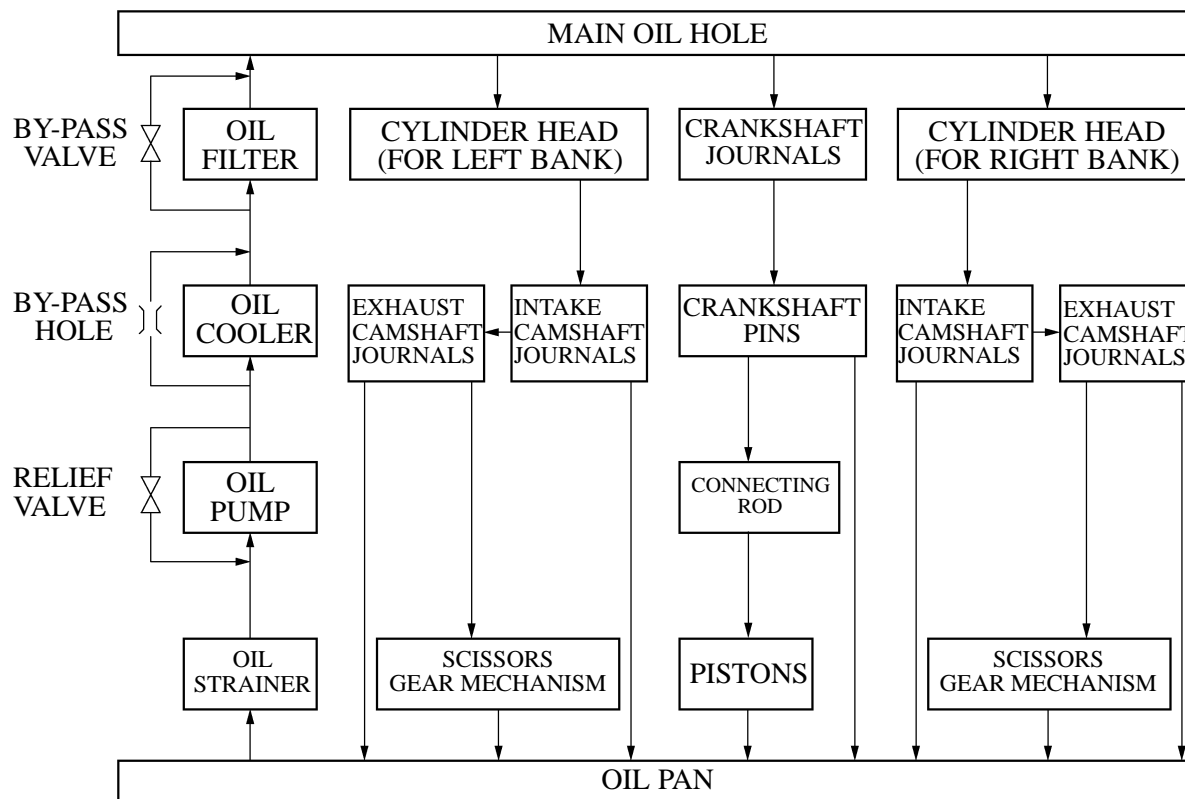
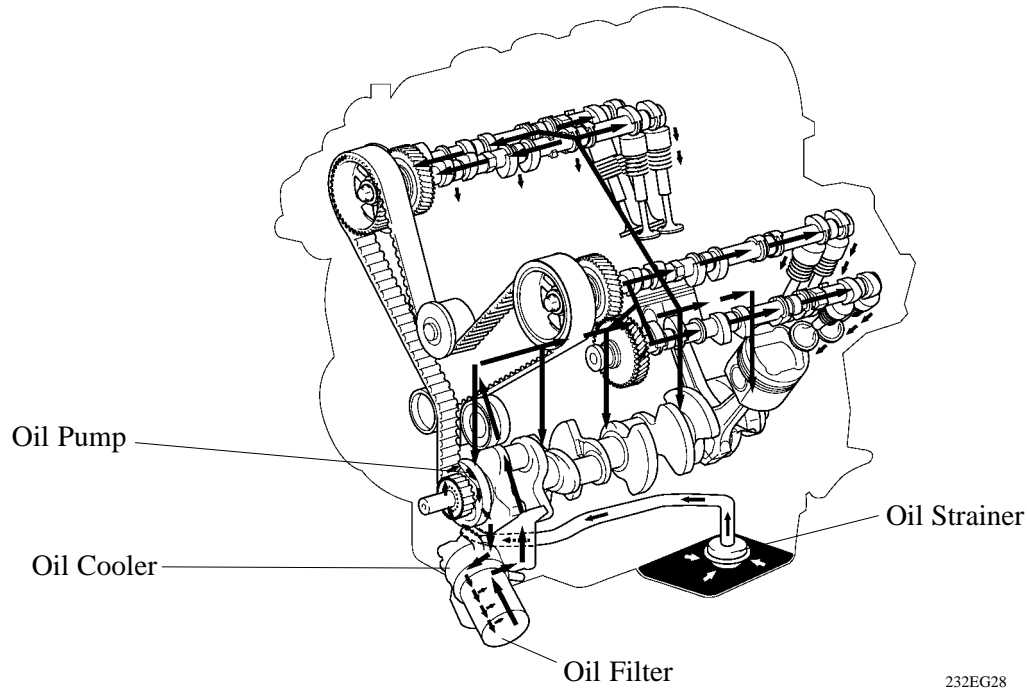

2. Oil Pan

- The oil pan is made up of 2 pieces. The No.1 oil pan is made of aluminum alloy and the No.2 oil pan is made of steel.
- The No.1 oil pan is secured to the cylinder block and the torque converter housing to increase rigidity.

