

■ PLANETARY GEAR UNIT

1. Construction

- The 5-speed configuration has been achieved using 3 (front, center, and rear) planetary gears, thus creating a 5-speed automatic transmission with practically the same dimensions as the previous (A340E, A340F) 4-speed automatic transmission.
- The front planetary carrier, made of aluminum, has been adopted to reduce the weight.
- A centrifugal fluid pressure canceling mechanism has been adopted in the C₁, C₂, and C₃ clutches that are applied when shifting from 2nd to 3rd, from 3rd to 4th and from 4th to 5th. For details, refer to page CH-10.

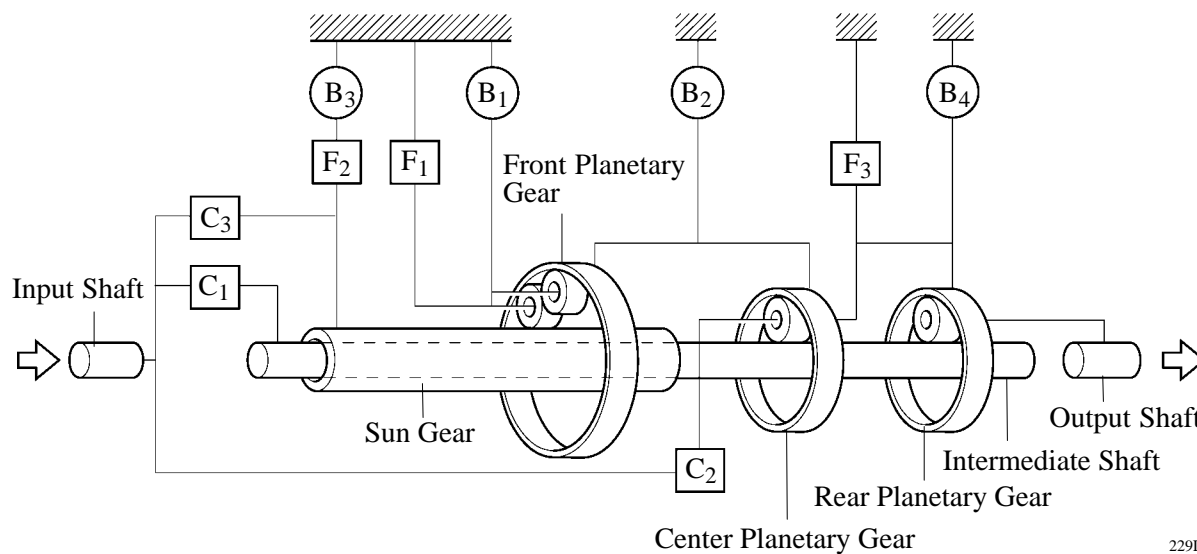

229LC160

2. Function of Component

Component		Function
C ₁	No.1 Clutch	Connects input shaft and intermediate shaft.
C ₂	No.2 Clutch	Connects input shaft and center planetary carrier.
C ₃	No.3 Clutch	Connects input shaft and front sun gear.
B ₁	No.1 Brake	Prevents front planetary carrier from turning either clockwise or counterclockwise.
B ₂	No.2 Brake	Prevents front and center ring gear from turning either clockwise or counterclockwise.
B ₃	No.3 Brake	Prevents outer race of F ₂ from turning either clockwise or counterclockwise.
B ₄	No.4 Brake	Prevents rear ring gear from turning either clockwise or counterclockwise.
F ₁	No.1 One-Way Clutch	Prevents front planetary carrier from turning counterclockwise.
F ₂	No.2 One-Way Clutch	When B ₃ is operating, prevents planetary sun gear from turning counterclockwise.
F ₃	No.3 One-Way Clutch	Prevents center planetary carrier and rear ring gear from turning counterclockwise.
Planetary Gears		These gears change the route through which driving force is transmitted, in accordance with the operation of each clutch and brake, in order to increase or reduce the input and output speed.

3. Transmission Power Flow

Shift Lever Position	Gear	Solenoid Valve						Clutch			Brake				One-Way Clutch		
		S1	S2	SR	SL ₁	SL ₂	SL _U	C ₁	C ₂	C ₃	B ₁	B ₂	B ₃	B ₄	F ₁	F ₂	F ₃
P	Park	ON				ON											
R	Reverse*	ON				ON				○	○			○	○		
N	Neutral	ON				ON											
D	1st	ON				ON		○									○
	2nd	ON	ON			ON		○					○		○	○	
	3rd		ON			ON		○		○			●		○		
	4th					ON		○	○	●			●				
	5th			ON	ON		ON		○	○	○			●			
4	1st	ON				ON		○									○
	2nd	ON	ON			ON		○					○		○	○	
	3rd		ON			ON		○		○			●		○		
	4th					ON	ON	○	○	●			●				
3	1st	ON				ON		○									○
	2nd	ON	ON			ON		○					○		○	○	
	3rd*		ON					○		○	○		●				
2	1st	ON				ON		○									○
	2nd*	ON	ON	ON				○					○	○			
L	1st*	ON						○									○

○: Operation

●: Operate but is not related to power transmission

* : with E/B (Engine Brake)

1st Gear (D Position)

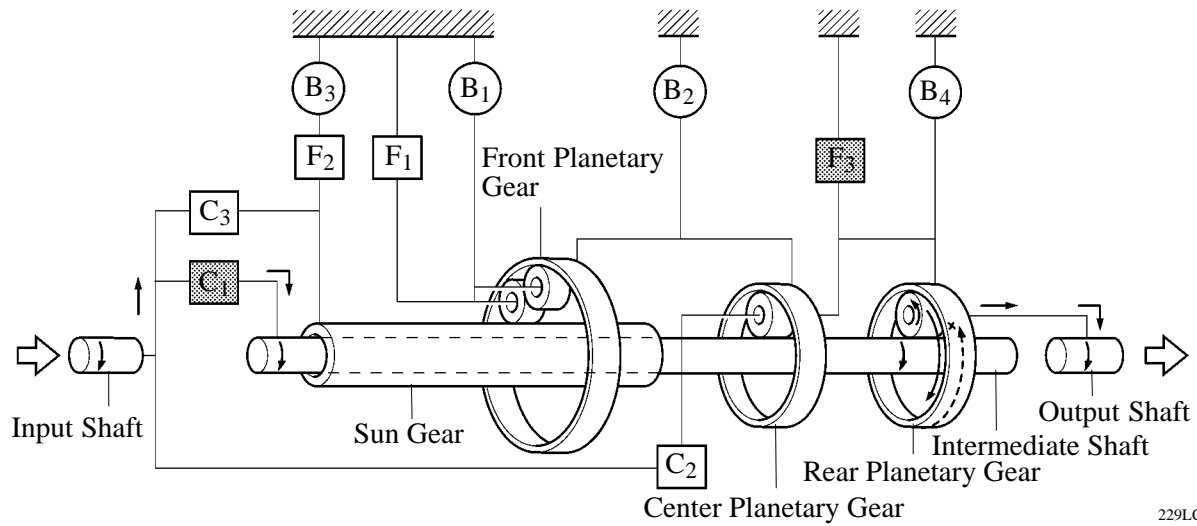

2nd Gear (D Position)

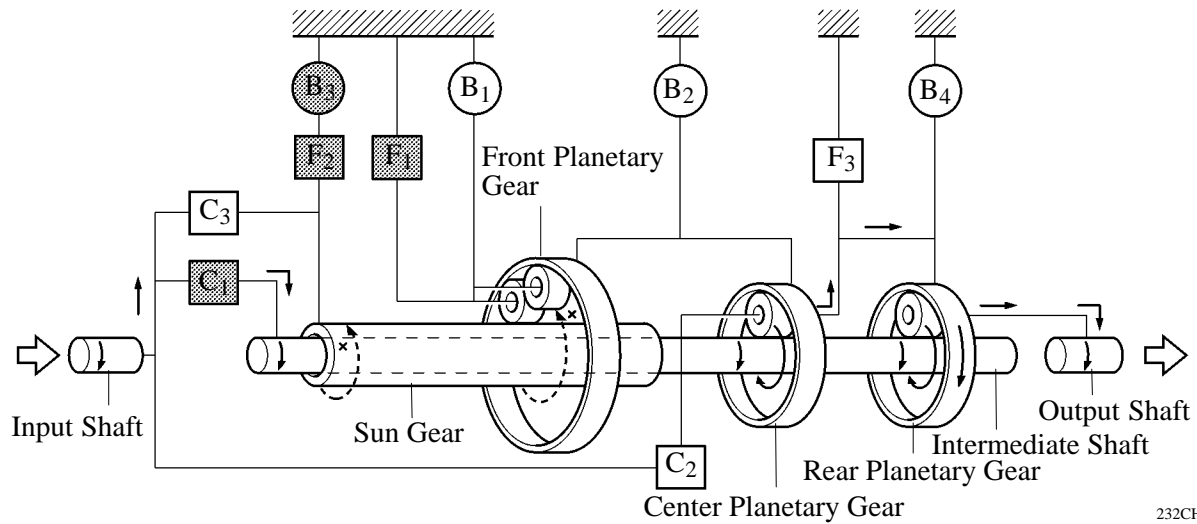

3rd Gear (D Position)

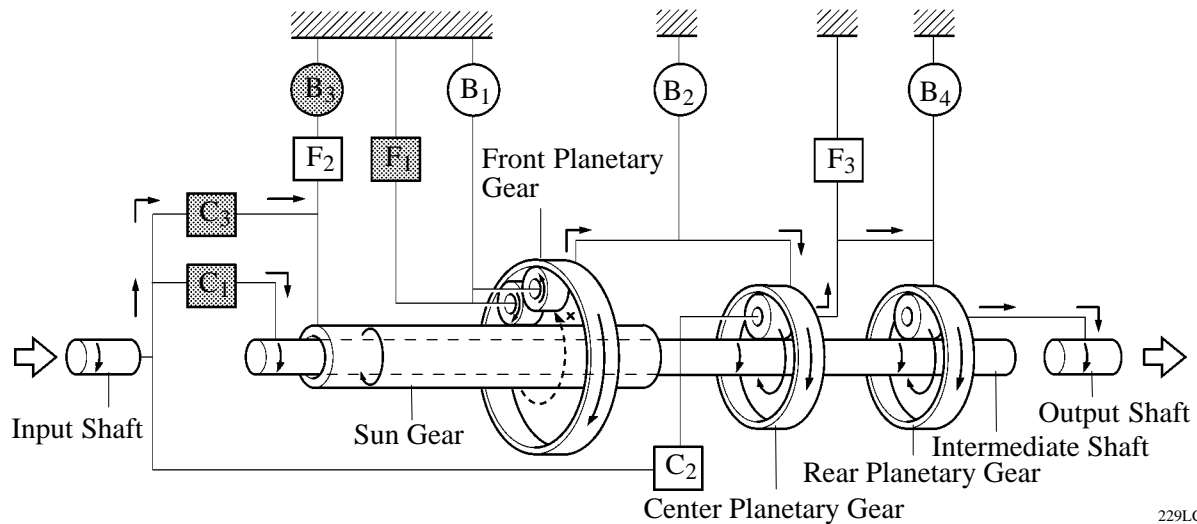

4th Gear (D Position)

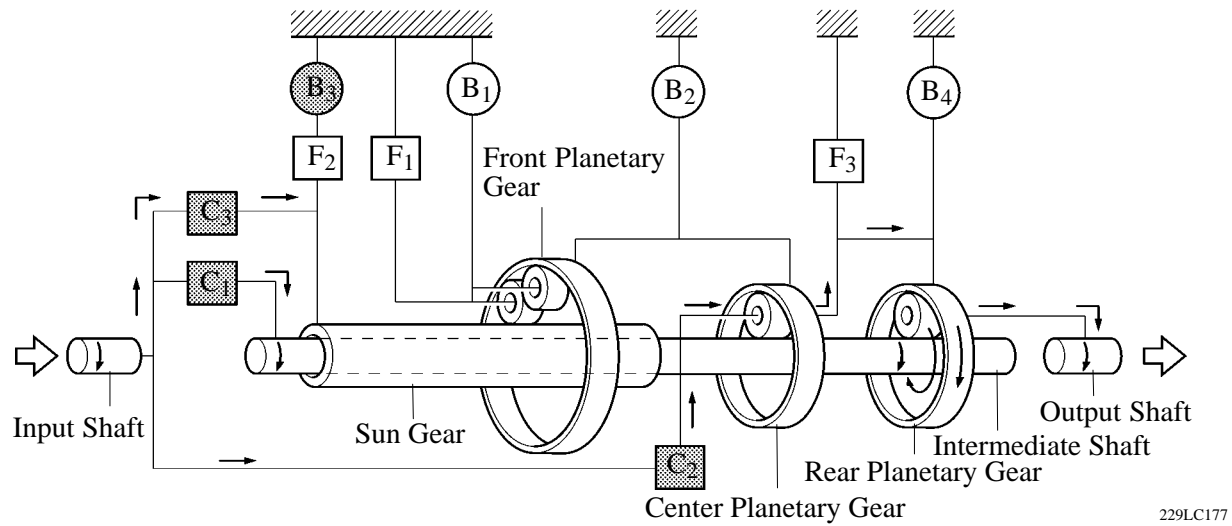

5th Gear (D Position)

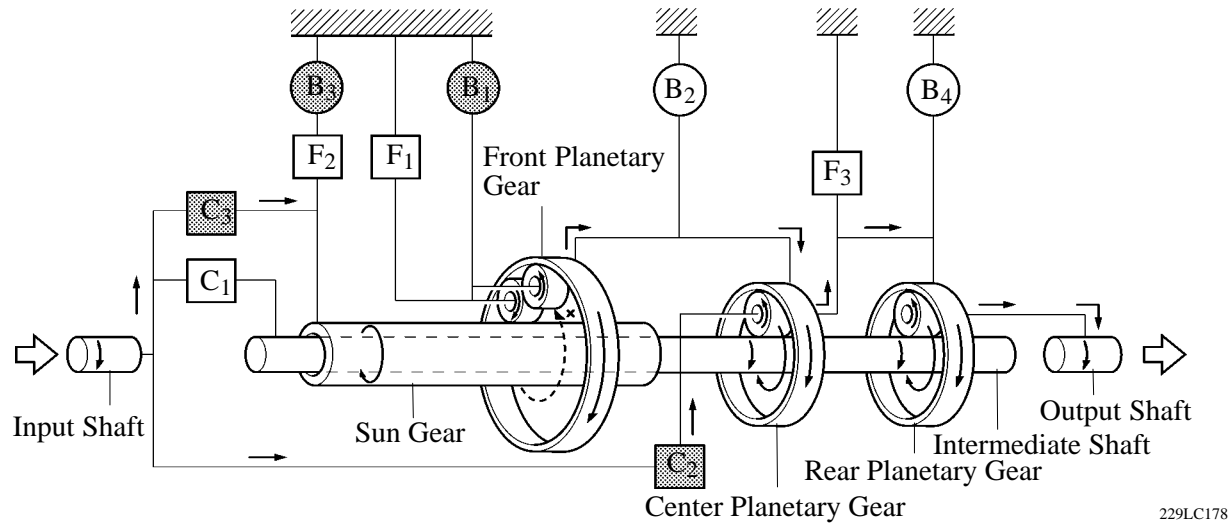

1st Gear (L Position)

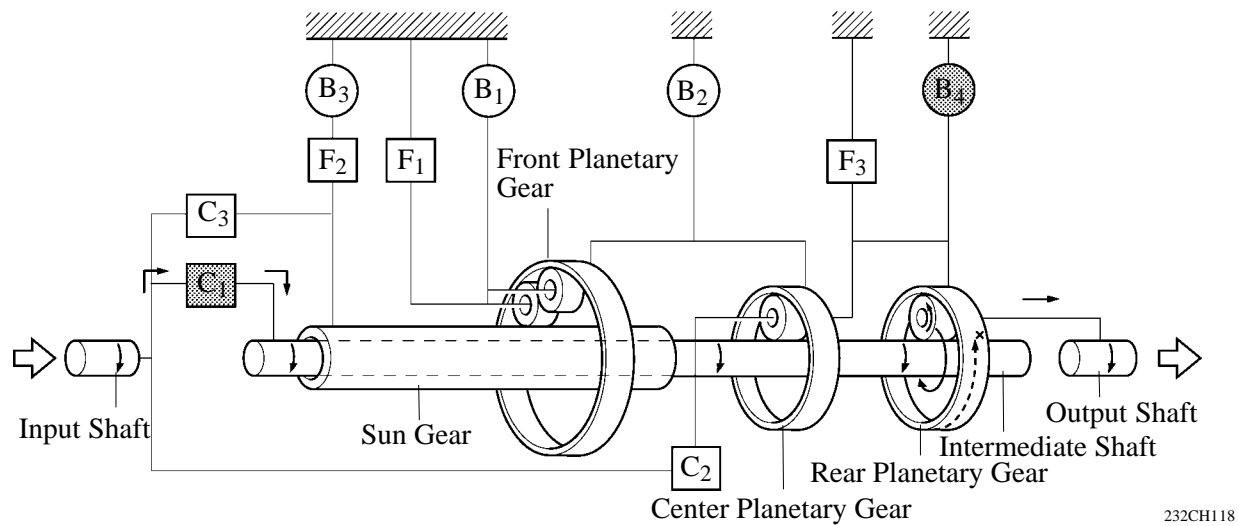

2nd Gear (2nd Position)

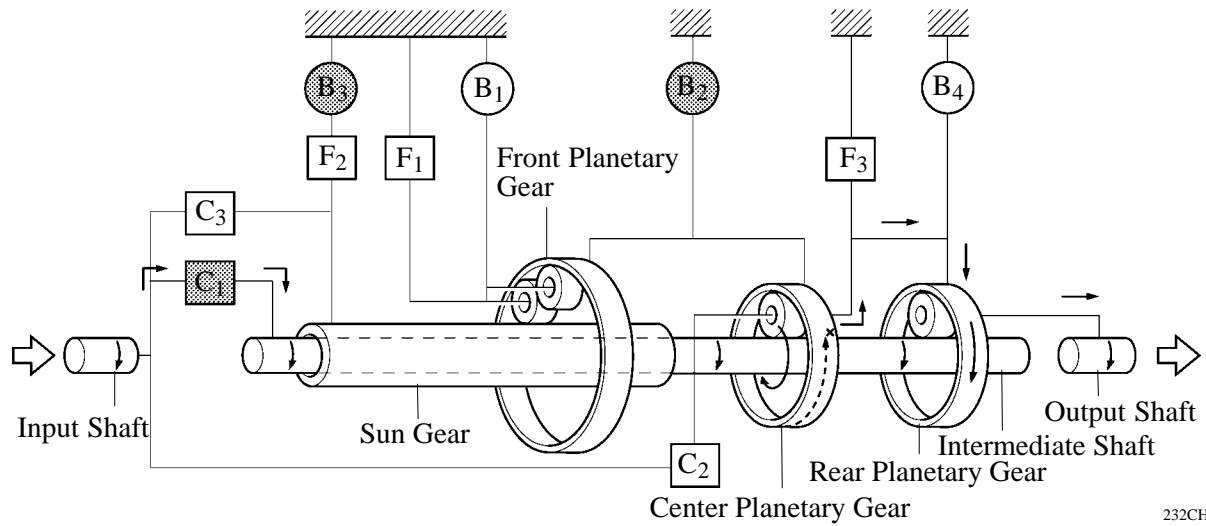

3rd Gear (3rd Position)

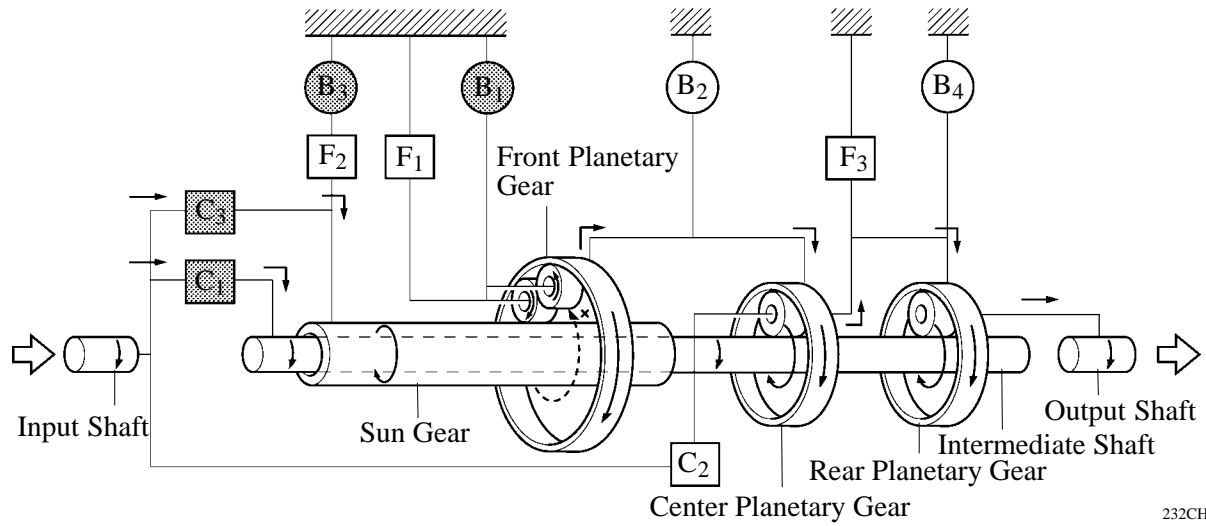

Reverse Gear (R Position)

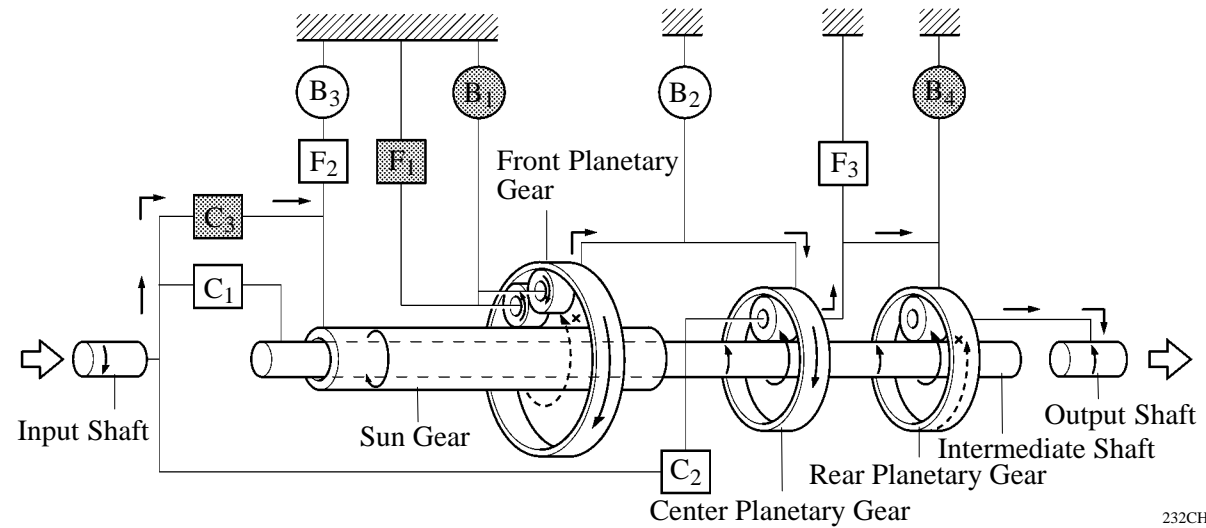

4. Centrifugal Fluid Pressure Canceling Mechanism

There are two reasons for improving the conventional clutch mechanism:

- To prevent the generation of pressure by centrifugal force applied to the fluid in the piston fluid pressure chamber (hereafter referred to as “chamber A”) when the clutch is released, a check ball is provided. Therefore, before the clutch could be subsequently applied, it took time to fill chamber A.
- During shifting, in addition to the original clutch pressure that is controlled by the valve body, centrifugal pressure acts on the fluid in the chamber A exerting increased pressure depending upon revolution fluctuations.

To address these two needs for improvement, a canceling fluid pressure chamber (hereafter referred to as “chamber B”) has been provided opposite chamber A.

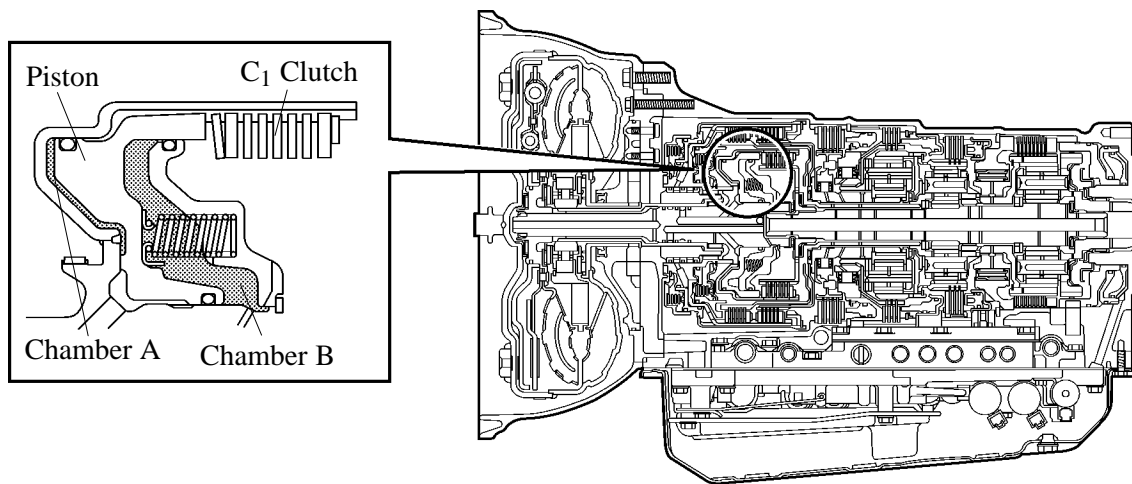

229LC168

By utilizing the lubrication fluid such as that of the shaft, the same amount of centrifugal force is applied, thus canceling the centrifugal force that is applied to the piston itself. Accordingly, it is not necessary to discharge the fluid through the use of a check ball, and a highly responsive and smooth shifting characteristic has been achieved.

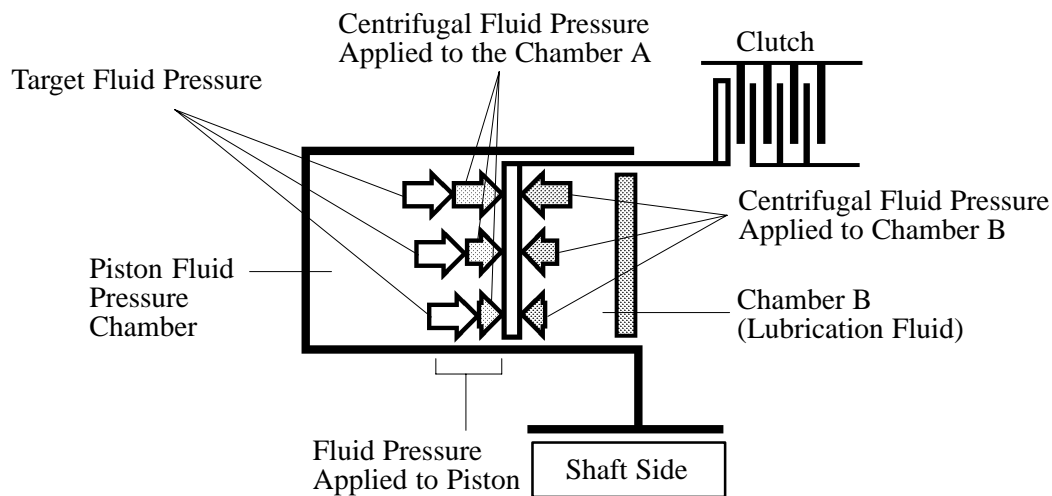

157CH17

Fluid pressure applied to piston	-	Centrifugal fluid pressure applied to chamber B	=	Target fluid pressure (original clutch pressure)
----------------------------------	---	---	---	--