

## ■ LOW VIBRATION, LOW NOISE BODY

### 1. General

An effective application of vibration damping and noise suppressant materials reduces engine and road noise.

### 2. Sound Absorbing And Vibration Damping Materials

- In place of the asphalt sheet used on the floor of the '02 model, the '03 model uses a coating-type vibration damping material to improve vibration damping performance and weight reduction.

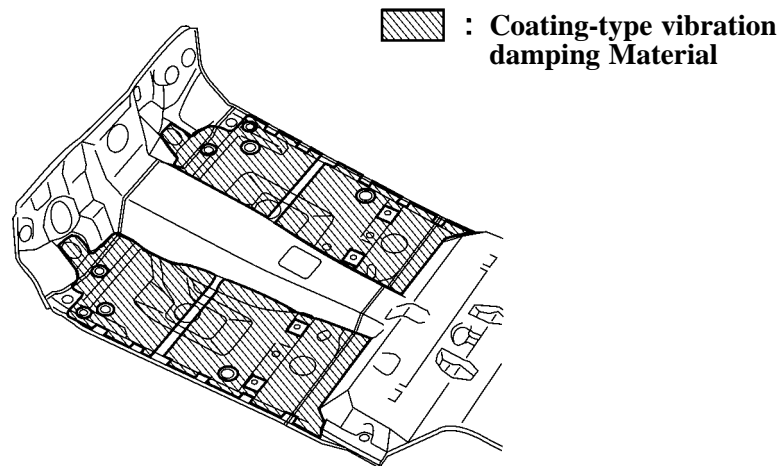

232BO16

- A foamed material and urethane pads have been applied to various areas to reduce wind and road noise.

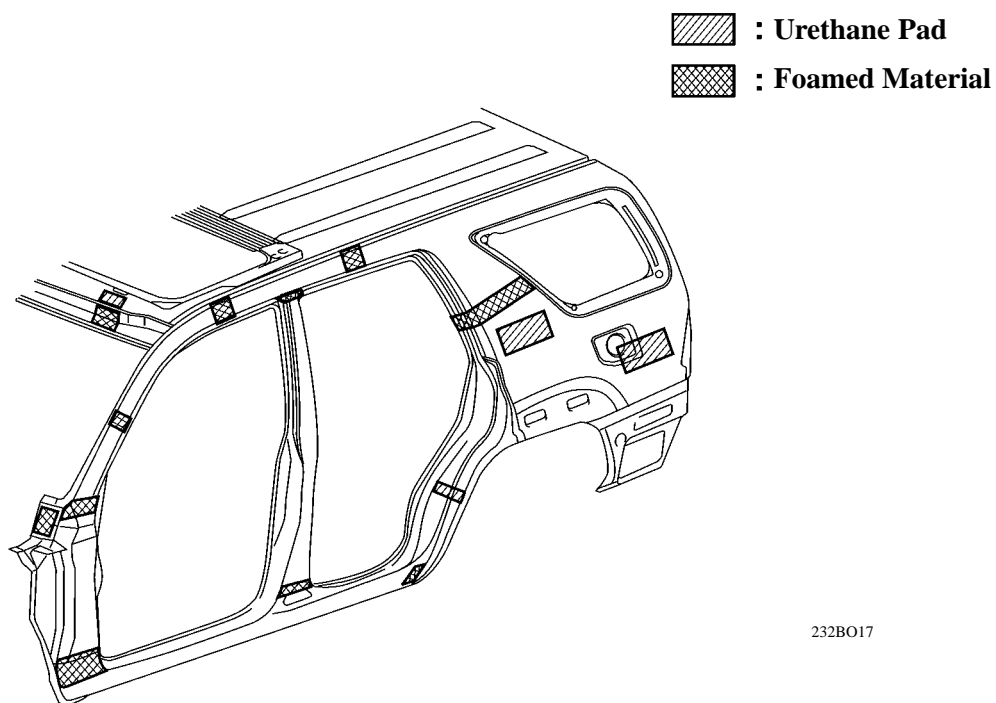

232BO17

- The layout and the cross section of the roof reinforcements have been optimized in order to generate vibrations at opposite phases, instead of the previous same-phase vibrations. As a result, the vibration on the roof panel has been significantly reduced, thus ensuring quieter operation.

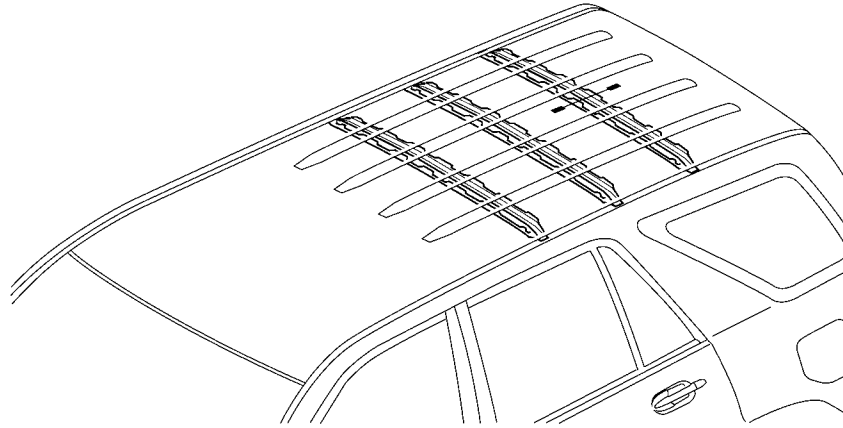

232B033

A – A Cross Section

► Vibrations ◀

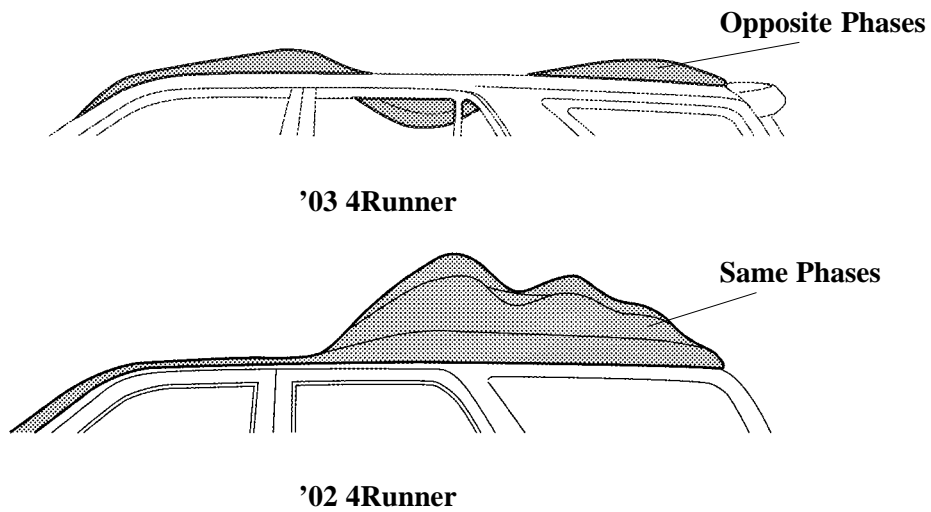

232B034

### 3. Cab Mounting

The structure of the cab mounts has been revised and the rubber cushion has been supplemented. Accordingly, the vehicle's riding comfort has been improved and noise and vibration have been reduced.

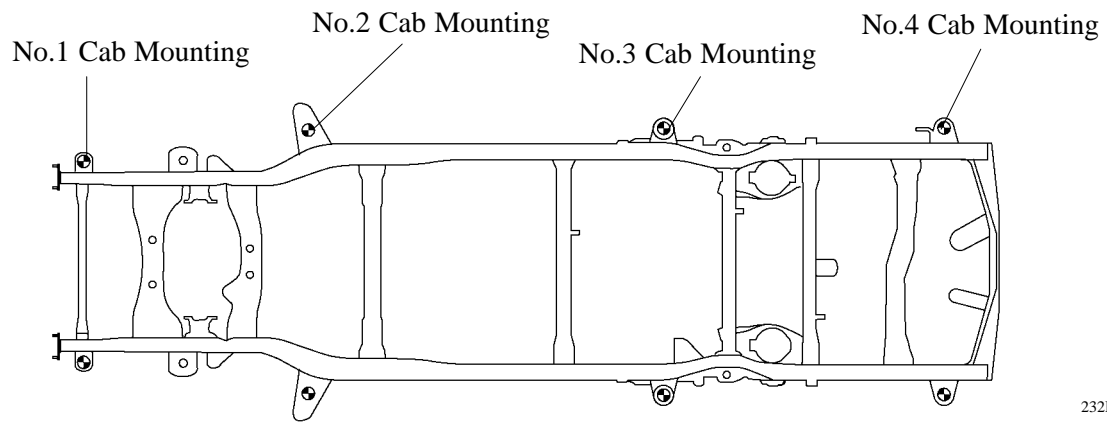

232BO18

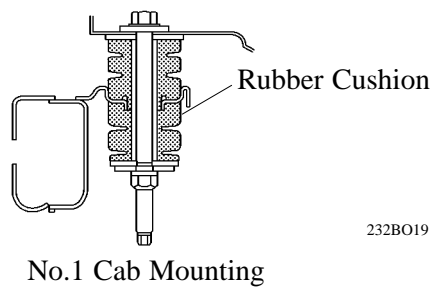

232BO19

No.1 Cab Mounting

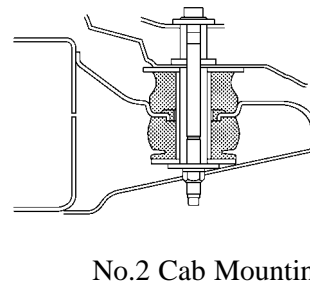

232BO20

No.2 Cab Mounting

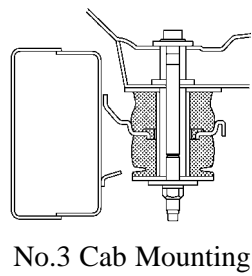

232BO21

No.3 Cab Mounting

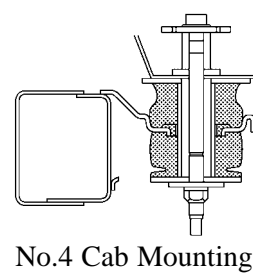

232BO22

No.4 Cab Mounting