

## ■ RUST-RESISTANT BODY

### 1. General

Rust-resistant performance is increased by using anti-corrosion sheet steel and anti-corrosion treatment by applying wax, sealer, anti-chipping paint, etc. to easily corroded parts such as the hood, doors, rocker panels, etc.

### 2. Anti-Corrosion Sheet Steel

Anti-corrosion sheet steel is used for many inner and outer panels of the body shell such as the dash panel, floor panels, hood, roof and doors, etc. in order to further improve rust-resistant performance.

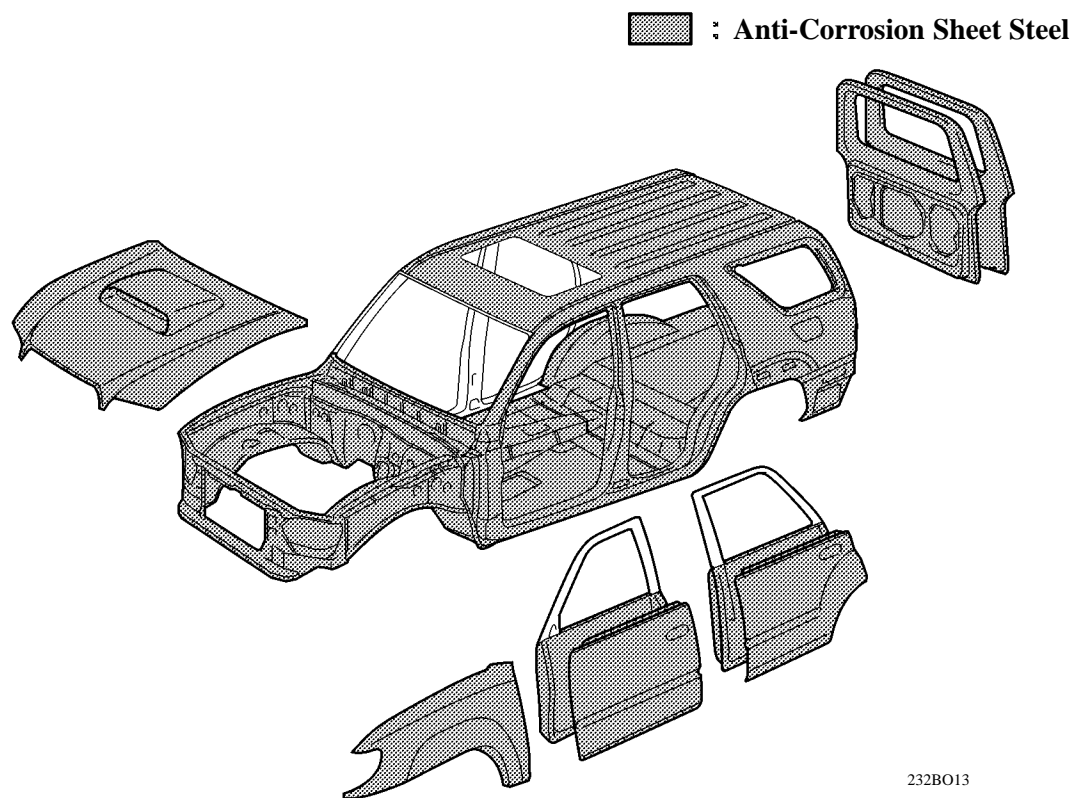



### 3. Wax And Sealer

Wax and sealer are applied to hemmed portions of the hood, door panels, hinge, tailgate and etc. to improve rust-resistant performance.

### 4. Under Coat

PVC (Polyvinyl Chloride) coating is applied to the under side of the body. The fender apron and other parts, which are subject to damage by flying stones, etc., are given a thick coating to improve rust-resistant performance.

-  : PVC Coating Area
-  : PVC Coating Area (Thick Coating)
-  : Edge Seal

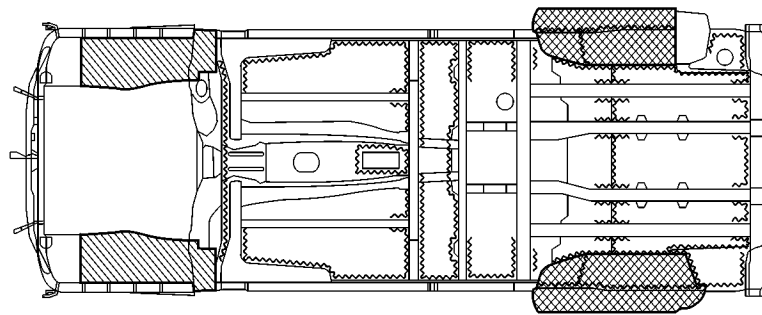

232B014

### 5. Anti-Chipping Application

Anti-chipping paint applied around the wheel housing of all models. In addition, PVC chipping primer is applied to the rocker panel area of the outside molding on side stepless model. Furthermore Soft-chip primer is applied to the front end of the hood.

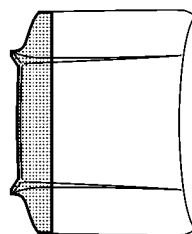

-  : Soft-Chip Primer
-  : PVC Chipping Primer
-  : Anti-Chipping Paint

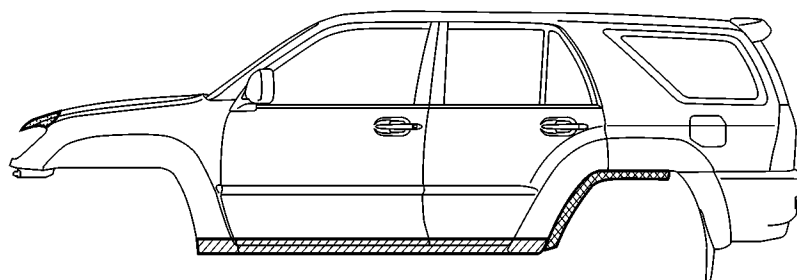

232B015