

## TRAC Operation

- The fluid pressure that is generated by the pump & pump motor is regulated by the accumulator cut solenoid valve STR to the required pressure. Thus, the wheel cylinders of the drive wheel are controlled in the following 3 modes: pressure reduction, pressure holding, and pressure increase modes, to restrain the slippage of the drive wheels.
- At this time, the skid control ECU outputs a TRAC operation signal to the ECM and the combination meter. Upon receiving this signal, the ECM effects throttle control to regulate the engine output. The combination meter causes the slip indicator light to blink.
- If the accumulator pressure drops during this operation, the skid control ECU receives the signals from the pressure switch PH and actuates the pump & pump motor to ensure the proper accumulator pressure.

### ► System Diagram ◀

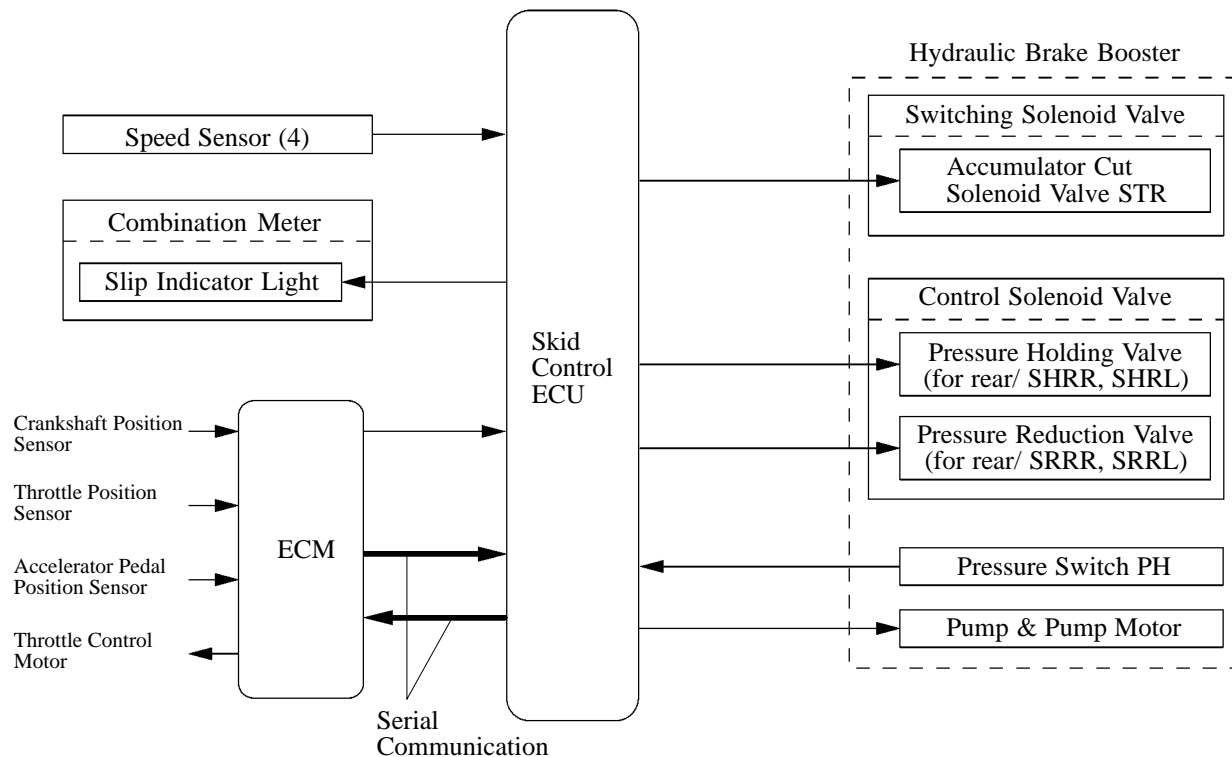

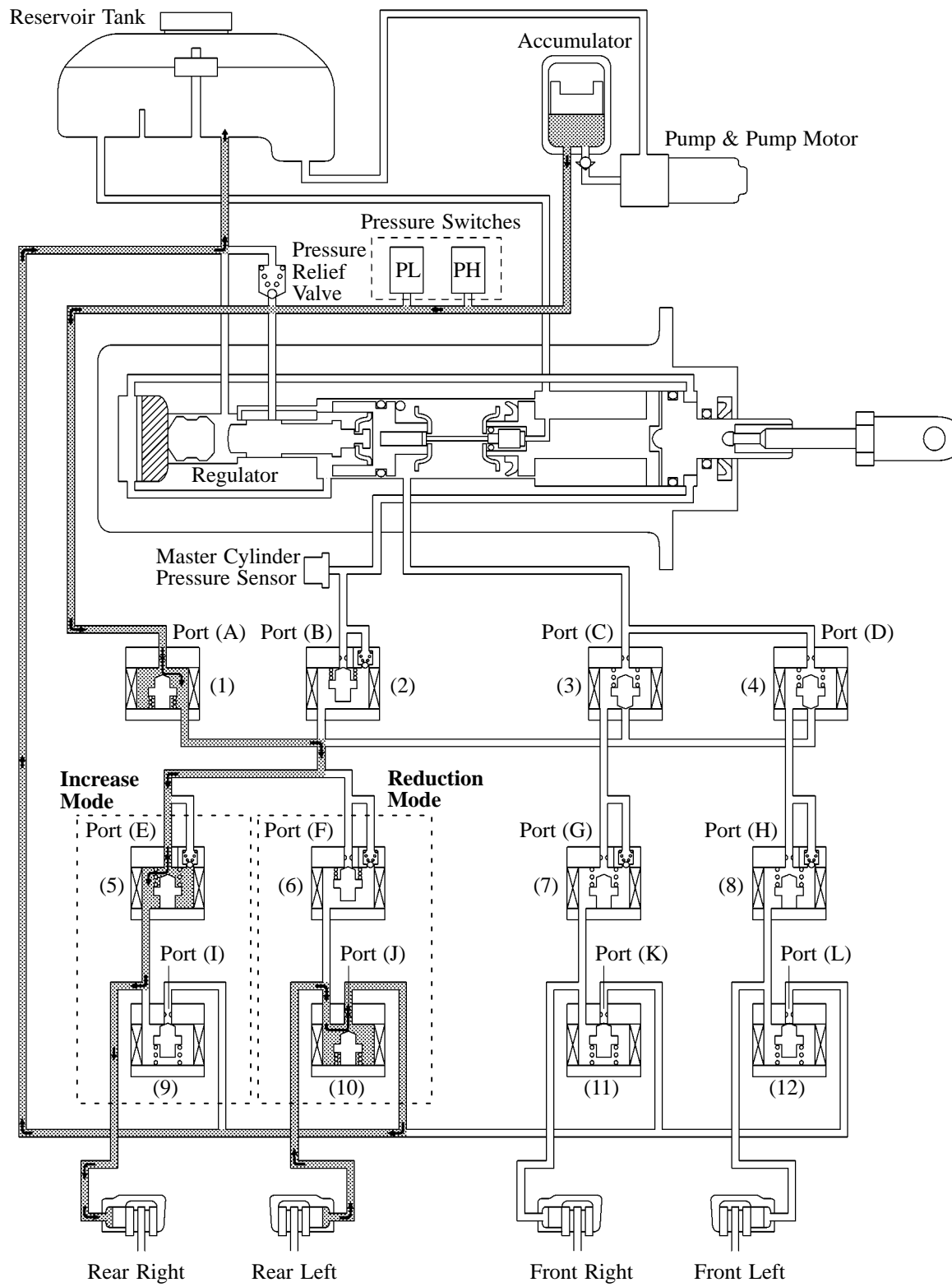

Item			TRAC not Activated	TRAC Activated			
				Increase Mode	Hold Mode	Reduction Mode	
Switching Solenoid Valve	(1)	Accumulator Cut Solenoid Valve STR	OFF (Close)	ON* (Open)	←	←	
		Port (A)					
	(2)	Regulator Cut Solenoid Valve SA3	OFF (Open)	ON (Close)	←	←	
		Port (B)					
	(3)	Master Cylinder Cut Solenoid Valve SA1	OFF (Open)	←	←	←	
		Port (C)					
	(4)	Master Cylinder Cut Solenoid Valve SA2	OFF (Open)	←	←	←	
		Port (D)					
Control Solenoid Valve	Front Brake	(7), (8)	Pressure Holding Valve	OFF (Open)	←	←	
			Port: (G), (H)				
		(11), (12)	Pressure Reduction Valve	OFF (Close)	←	←	←
			Port: (K), (L)				
	Wheel Cylinder Pressure		—	—	—	—	
	Rear Brake	(5), (6)	Pressure Holding Valve	OFF (Open)	←	ON (Close)	←
			Port: (E), (F)				
		(9), (10)	Pressure Reduction Valve	OFF (Close)	←	←	ON (Open)
Port: (I), (J)							
Wheel Cylinder Pressure		—	Increase	Hold	Reduction		

\*: The accumulator cut solenoid valve STR controls the hydraulic pressure between “open” through “close” according to the operating condition by adjusting continually.

#### — TRAC OFF Condition —

- When the TRAC OFF switch is pressed once with the ignition switch ON, the skid control ECU causes the TRAC to turn OFF and the TRAC OFF indicator light to turn OFF. When the TRAC OFF switch is pressed the second time, the skid control ECU causes the TRAC to turn ON and the TRAC OFF indicator light to turn OFF.
- When the vehicle speed is approximately 30 km/h (19 mph) or higher, the TRAC OFF condition cancels automatically, allowing the TRAC to turn ON. Once this cancel operation takes place, the TRAC will not turn OFF even if the TRAC OFF switch is operated again when the vehicle speed is below approximately 30 km/h (19 mph).
- It will resume by turning it ON with the ignition switch turned OFF.