

### ■ CRUISE CONTROL SYSTEM

#### 1. General

- Once the system is set to a desired vehicle speed, the throttle valve position is adjusted automatically to maintain the vehicle speed at that speed without depressed the accelerator pedal.
- This system, which is available as standard on the '03 4Runner effects control through the ETCS-i system.

#### 2. System Diagram

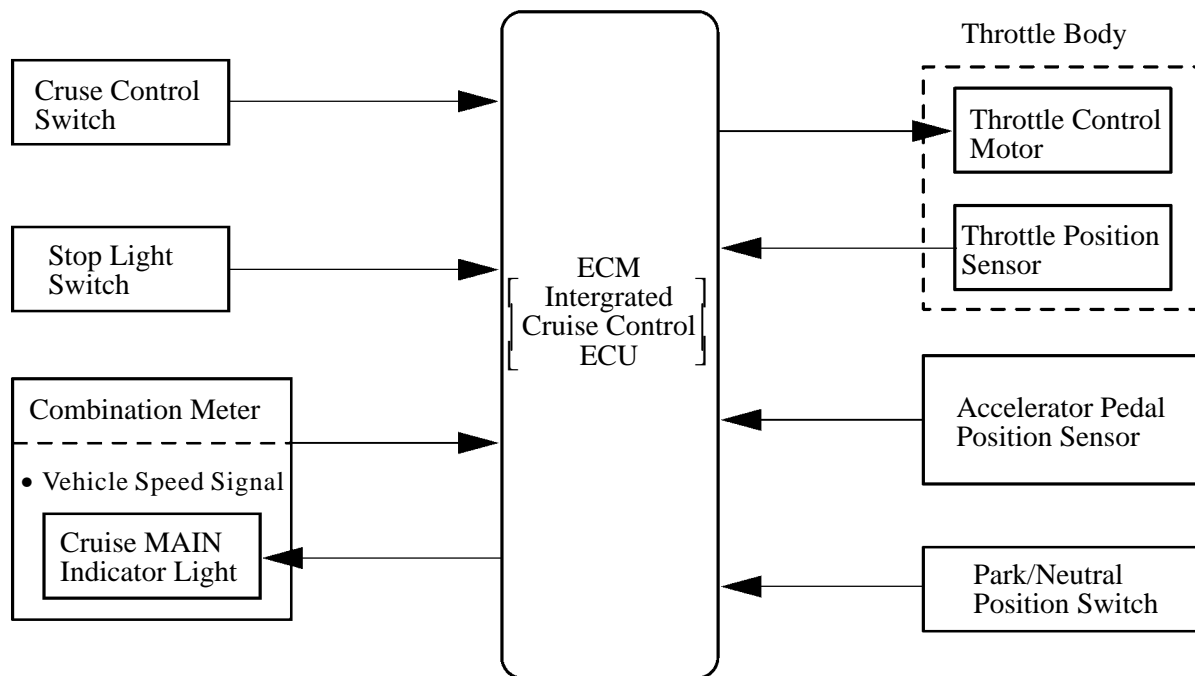

### 3. Layout of Main Component

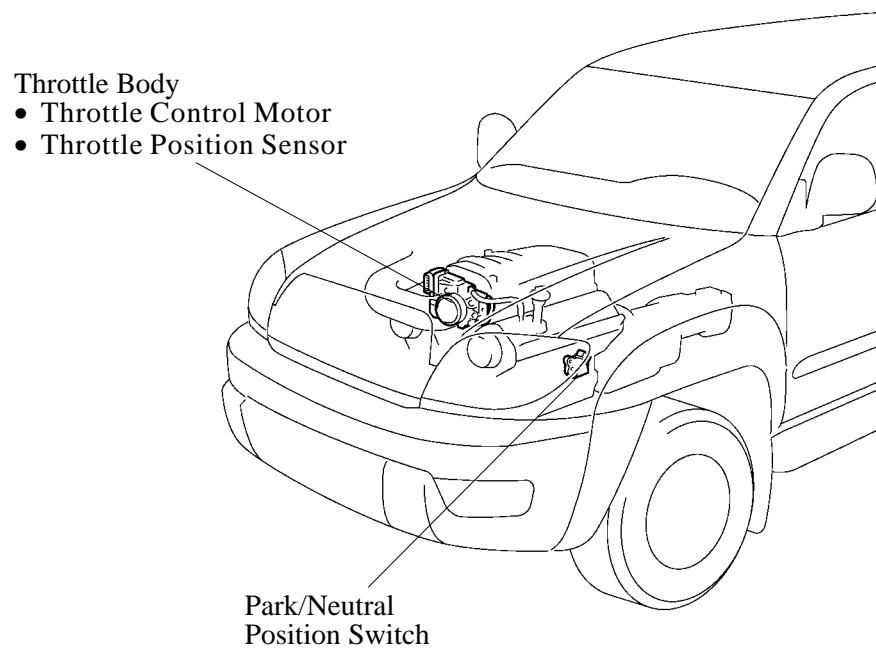
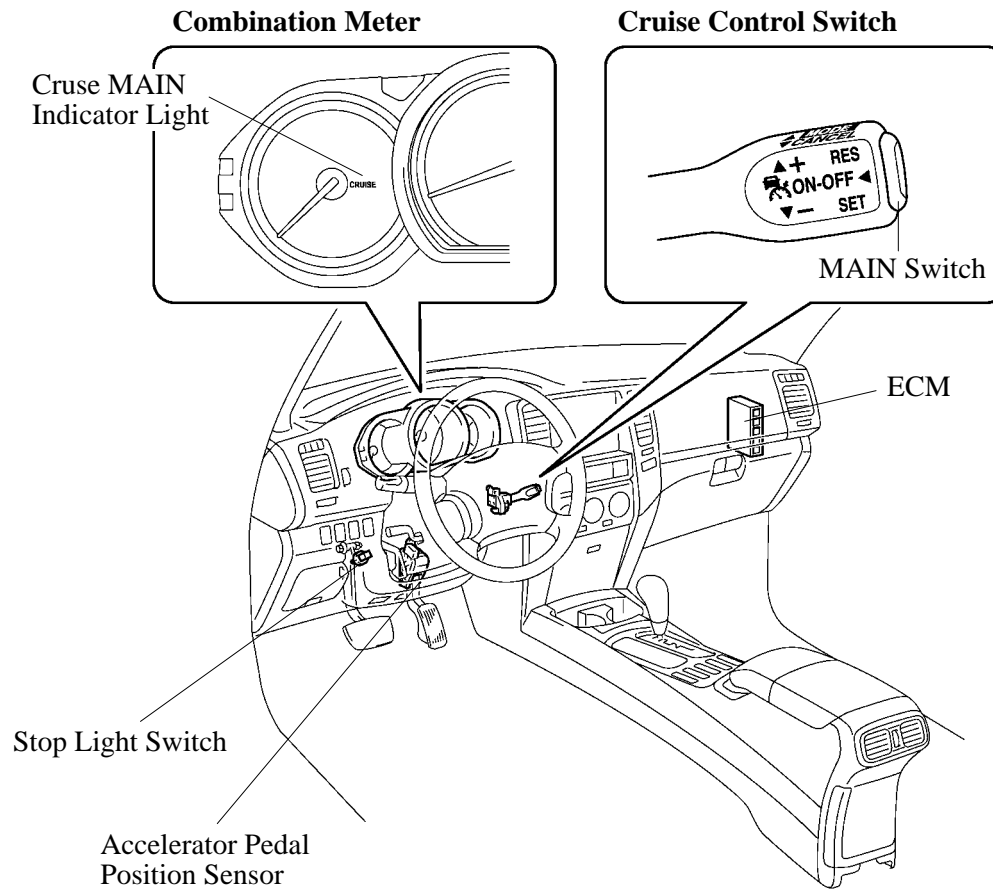

#### 4. Function

The cruise control has the following functions.

Function	Outline
Constant Speed Control	The ECM (integrated cruise control ECU) compares the actual vehicle speed and the set speed and if the vehicle speed is higher than the set speed, it activates the throttle control motor in the throttle closing direction. If the vehicle speed is lower than the set speed, it activates the throttle motor in the throttle opening direction.
Set Control	When the cruise control switch is pressed to the SET/COAST side and released while the vehicle is running within a cruising speed control range [approx. 25 mph (40 km/h) or more] with the MAIN switch turned on, the ECM (integrated cruise control ECU) stores the vehicle speed and controls it at that speed constantly.
Low Speed Limit Control	The low speed limit is the lowest speed that cruise control can be set and is designed at approx. 25 mph (40 km/h). The cruise control cannot be set below that speed. If the vehicle speed drops below that speed while running in the cruise control mode, the cruise control is cancelled automatically and the set speed in the memory is cleared.
Accelerator Control	When the cruise control switch is kept pushed to the RES/ACC side while running in the cruise control mode, the throttle control motor is energized in the throttle opening direction. The vehicle keeps accelerating and the ECM (integrated cruise control ECU) stores the vehicle speed when the hand is released from the cruise control switch. From then on, the ECM (integrated cruise control ECU) controls the vehicle speed at that speed constantly
Tap-Up Control	When the difference between the actual vehicle speed and the set speed is less than 3 mph (5 km/h), the set speed can be increased approx 1 mph (1.6 km/h) each time by operating the RES/ACC switch quickly within approx 0.5 seconds.
Coast Control	When the cruise control switch is kept pushed to the SET/COAST side while running in the cruise control mode, the throttle control motor is energized in the throttle closing direction. The vehicle keeps decelerating the ECM (integrated cruise control ECU) stores the vehicle speed when the hand is released from the cruise control switch. From then on, the ECM (integrated cruise control ECU) controls the vehicle speed at that speed constantly
Tap-Down	When the difference between the actual vehicle speed and the set speed is less than 3 mph (5 km/h), the set speed can be lowered approx. 1 mph (1.6 km/h) each time by operating the SET/COAST switch quickly within approx. 0.5 seconds
Resume Control	After the cruise control mode is cancelled by any of the cancel switches, the mode can be resumed and controlled at the set speed by operating the cruise control switch in the RES/ACC direction providing that the vehicle speed has not dropped below the low speed limit [approx. 25 mph (40 km/h)]. The mode cannot be resumed if the vehicle speed once drops below the low speed limit, because the speed in the memory is cleared.
Manual Cancel Control	If any of the following signals is sent to the ECM (integrated cruise control ECU) while the vehicle is running in the cruise control mode, the cruise control mode is cancelled accordingly. <ul style="list-style-type: none"> <li>• Stop light switch ON signal (Depress the brake pedal)</li> <li>• D position circuit in Park/Neutral position switch OFF signal (Shift the transmission shift lever from D to N, 2, or L)</li> <li>• CANCEL switch ON signal</li> <li>• MAIN switch OFF signal</li> </ul>

Automatic Cancel Control	<p>When any of the following conditions occur during cruise control driving, the speed that is set in the memory is cleared to cancel the cruise control mode. Furthermore, the cruise main indicator light blinks until the MAIN switch is turned OFF, and the operation of the cruise control is disabled until the MAIN switch is turned ON again.</p> <ul style="list-style-type: none"> <li>• Stop light switch open or short circuit</li> <li>• The vehicle speed signal is not set for a predetermined period of time (approx. 140 msec)</li> <li>• ETCS-i malfunction</li> </ul>
	<p>When any of the following conditions occur during the cruise control driving, the speed that is set in the memory is cleared to cancel the cruise control mode. Furthermore, the cruise main indicator light blinks until the MAIN switch is turned OFF, and the operation of the cruise control is disabled until the ignition switch is turned OFF again.</p> <ul style="list-style-type: none"> <li>• Stop light switch input signal abnormal</li> <li>• Cruise control switch input signal abnormal</li> </ul>
	<p>When any of the following conditions occurs during the cruise control driving, the set speed in the memory is cleared to cancel the cruise control mode. Cruise control can be resumed at the set speed by operating the SET or RESUME switch providing that the vehicle speed is above the lower speed limit [approx. 25 mph (40 km/h)].</p> <ul style="list-style-type: none"> <li>• The vehicle speed falls below the low speed limit [approx. 25 mph (40 km/h)]</li> <li>• The vehicle speed drops more than 10 mph (16 km/h) below the set speed as in uphill driving</li> </ul>
Automatic Transmission Control	<p>When the vehicle is cruising uphill, there is a case where the overdrive turns off depending on the ECT control. After that, when the ECM judges the end of cruising up from the throttle valve opening angle, the overdrive will turn on again after about 3 seconds. Also, in case that the overdrive turns off during accelerator or resume control, it will turn on after finishing accelerator or resume control.</p>
Diagnosis	<p>When the ECM (integrated cruise control ECU) does not receive a vehicle speed signal for a predetermined period of time during cruising, or when cruise control is cancelled (automatic cancel) by a malfunction in the cruise control switch, stop light switch or vehicle speed signal, the ECM (integrated cruise control ECU) immediately blinks the cruise main indicator light on the combination meter on and off five times to alert the driver of the system malfunction. The contents of malfunctions are coded and stored in the ECM (integrated cruise control ECU).</p>

## 5. Diagnosis

- When the ECM (integrated cruise control ECU) does not receive a vehicle speed signal for a predetermined period of time during cruising, or when cruise control is cancelled (automatic cancel) by a malfunction in the cruise control switch, stop light switch or vehicle speed signal, the ECM (integrated cruise control ECU) immediately blinks the cruise main indicator light on the combination meter on and off five times to alert the driver of the system malfunction. The contents of malfunctions are coded and stored in the ECM (integrated cruise control ECU).
- The DTC (Diagnostic Trouble Code) can be accessed by connecting a hand-held tester to DLC3 terminal or the SST (09843-18040) to the Tc and CG terminals of the DLC3 and reading the blinking of the cruise main indicator light.  
A hand-held tester can be used to read 5-digit codes. With the SST, 2-digit codes can be read from the number of blinks of the cruise main indicator light. For details, see the 2003 4Runner Repair Manual (Pub. No. RM1001U).
- The DTC listed below is used.

DTC No.	Detection Item	DTC No.	Circuit Inspection
5-digit		2-digit	
P0500	Vehicle Speed Sensor "A"	21	Vehicle Speed Sensor Circuit Open
P0503	Vehicle Speed Sensor "A" Intermittent/Erratic/High	23	Vehicle Speed Signal Abnormal
P0571	Brake Switch "A" Circuit	52	Stop Light Switch Circuit Open or Short
P0607	Control Module Performance	54	Input Signal Abnormal