

ENGINE IMMOBILISER SYSTEM

1. General

- This system has been provided on the all models as standard equipment.
- The engine immobiliser system is theft deterrent system which disables the engine from starting using the ignition key with an ID code that matched is the pre-registered code in the vehicle. This system consists of the transponder chip, coil, amplifier, and immobiliser ECU. The immobiliser ECU is enclosed in the ECM. This system adopts a transponder system which uses a transponder chip embedded in the grip of the ignition key. When the coil located around the ignition key cylinder receives the ID code signal transmitted by the transponder chip, the ECM determines whether or not the ID code matches the code stored.

► System Diagram ◀

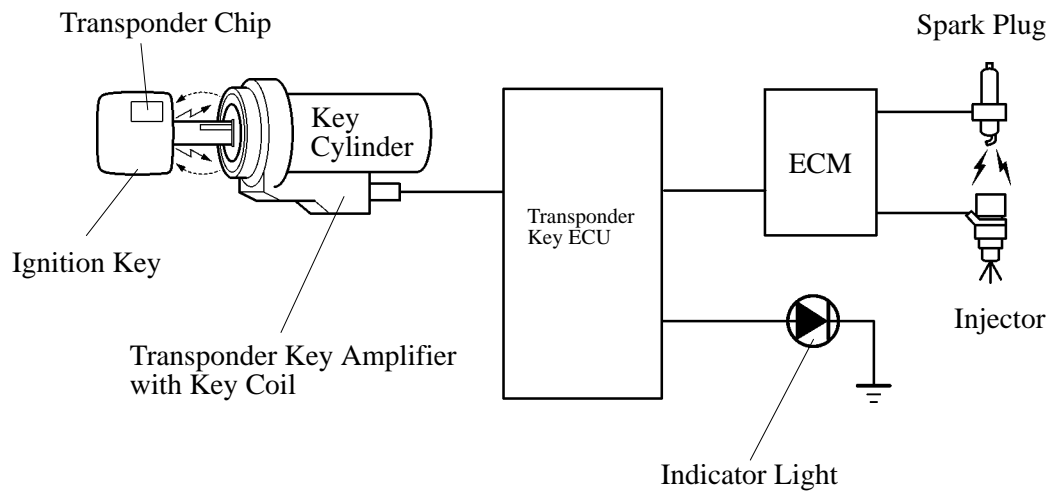

232BE45

Service Tip

In case of making new ignition key due to the loss of it, it is necessary to register ID code. Refer to see the 2003 4Runner Repair Manual (Pub. No. RM1001U).

2. Layout of Main Component

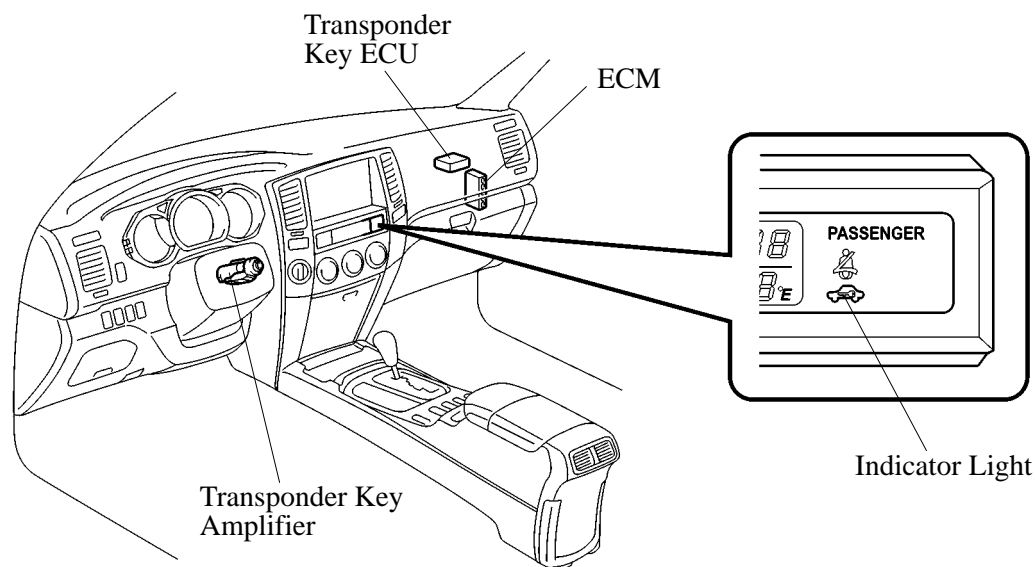

232BE42