

PERFORMANCE

Engine

2UZ-FE Engine

This V8, 4.7L, DOHC 32-valve engines generates a high torque of 320ft·lbf at low rpm. The torque with a sufficient reserve in the low-to-medium speed range realizes easy driving and excellent acceleration.

Specifications

Engine Type	2UZ-FE
No. of Cyls. & Arrangement	8-Cylinder, V Type
Valve Mechanism	32-Valve DOHC, Belt & Gear Drive
Displacement	4664 cm ³ (284.6 cu. in.)
Bore × Stroke	94.0 mm × 84.0 mm (3.70 in. × 3.31 in.)
Compression Ratio	9.6 : 1
Maximum Output [SAE-NET]	175 kW / 4800 rpm (235 HP @ 4800 rpm)
Maximum Torque [SAE-NET]	434 N·m / 3400 rpm (320 ft·lbf @ 3400 rpm)

► Cross Section Drawing ◀

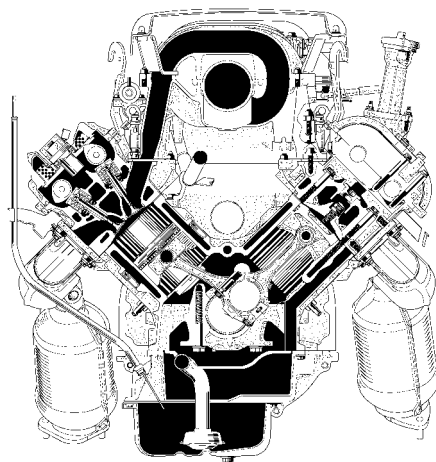

232EG24

► Performance Curve ◀

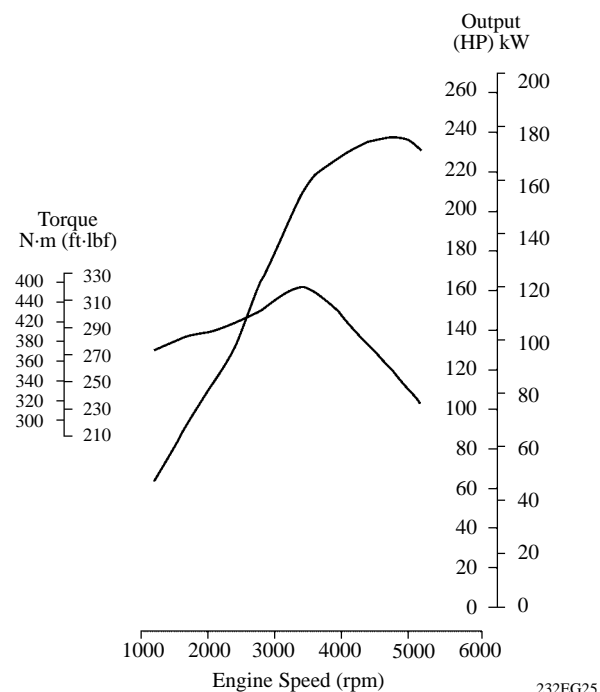

232EG25

ETCS-i (Electronic Throttle Control System-Intelligent)

The ETCS-i uses ECM to calculate the optimal throttle valve opening that is appropriate for the respective driving condition and used a throttle control motor to control the opening.

Automatic Transmission

The 5-speed A750E and A750F automatic transmissions, “Super ECT (Electronically Controlled Transmission)”, which have been adopted for the 2WD (A750E) and 4WD (A750F) models, are compact and realize a high level of response and smooth shifting.

Gear Ratios

Engine Type		2UZ-FE	
Drive Type		2WD	4WD
Transmission Type		A750E	A750F
Gear Ratios	1st	3.520	
	2nd	2.042	
	3rd	1.400	
	4th	1.000	
	5th	0.716	
	Reverse	3.224	

Transfer

- The VF4BM type is used in the transfer with TORSEN* LSD built into the center differential to accomplish a limited slip effect. (*: TORSEN is ZEXEL's registered trademark.)

► VF4BM Transfer ◀

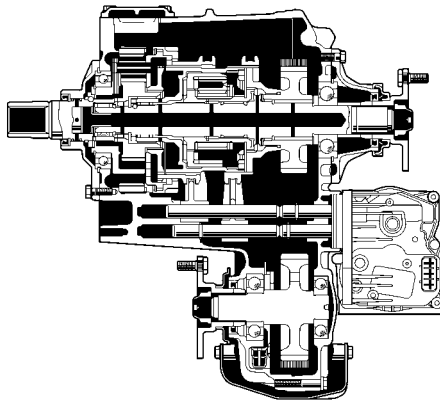

232CH51

► 4WD Control Switch ◀

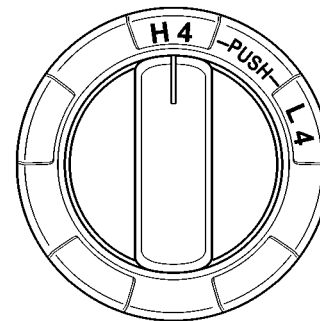

232CH52

4WD System

A TORSEN LSD is provided in the transfer unit of the 4WD system. The TORSEN LSD restrains the slippage of the wheels by automatically and instantly varying the torque distribution ratio between the front and rear wheels in accordance with driving conditions. In this 4WD system, the basic front/rear torque distribution for straightline driving is set to 40:60 to improve the vehicle's response during the initial stage of a turn. During the acceleration stage of a turn, this system automatically distributes torque in favor of the rear wheels.

Conceptual Image of 4WD System Operation

► During Normal Driving ◀

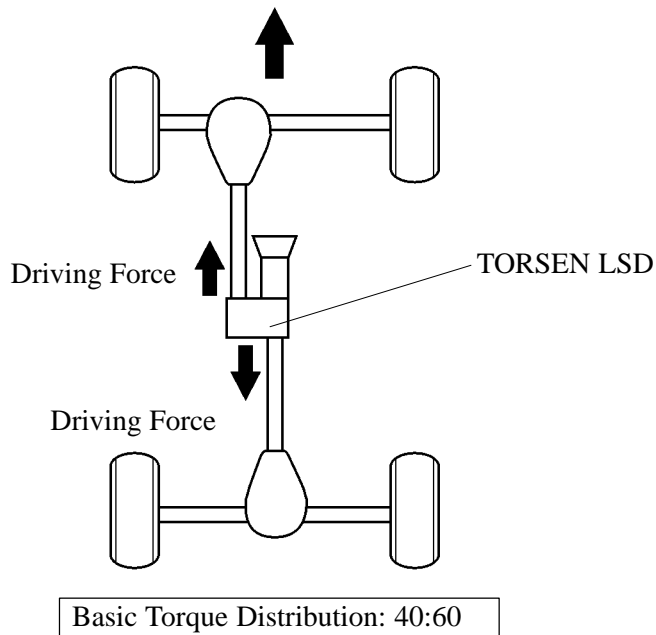

► During Rear Wheel Slippage ◀

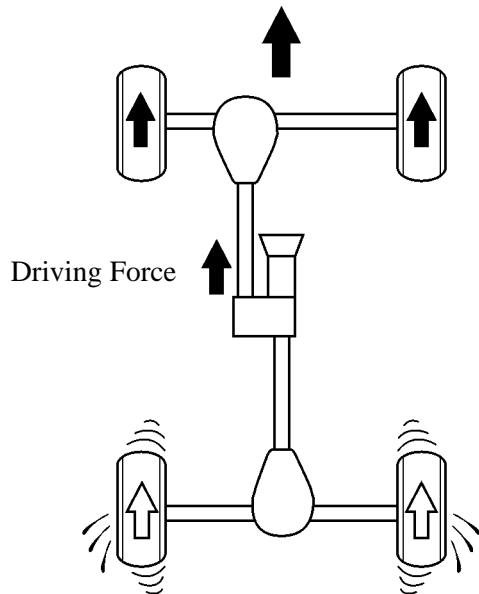

Torque distribution in favor of front wheels, in contrast to basic distribution

► During Cornering Acceleration ◀

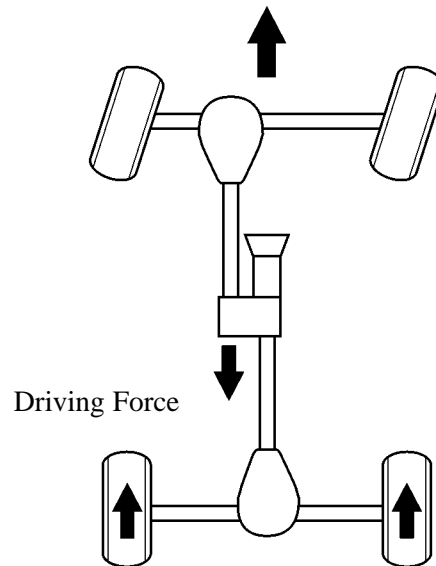

Torque distribution in favor of rear wheels, in contrast to basic distribution

Suspension

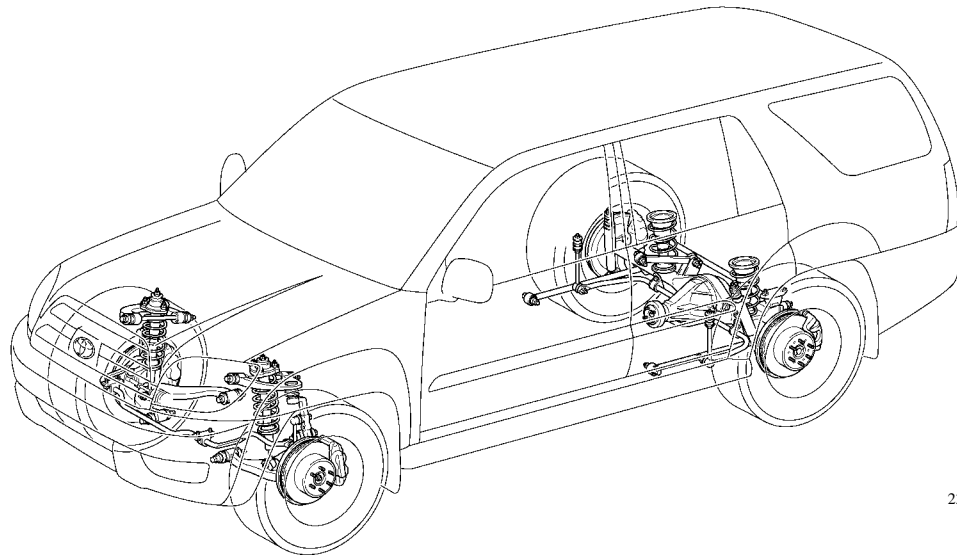

232MO21

For 4WD Model

Front Suspension

As on the '02 model, the front suspension is the double-wishbone type.

- The suspension geometry has been optimized to realize both excellent driving stability and ride comfort.
- N₂ gas sealed shock absorbers, which are placed upright to ensure excellent ride comfort, are used.
- The stabilizer has been relocated from the lower arms to the steering knuckles, and ball joints are used at both ends of the stabilizer link to improve the rolling rigidity of the vehicle.

Rear Suspension

As on the '02 model, the new model uses 4-link type rear suspension with lateral rods.

- The location of the control arms and the characteristics of the bushings have been revised to ensure excellent driving stability and ride comfort.
- The shock absorbers have been optimally located to ensure excellent driving stability and ride comfort.

X-REAS (X-Relative Absorber System)

- A reciprocal shock absorber system called the X-REAS (Relative Absorber System), which enhances the vehicle's driving performance by comprehensively controlling the suspension movement of the four wheels, is available as an option on all models.

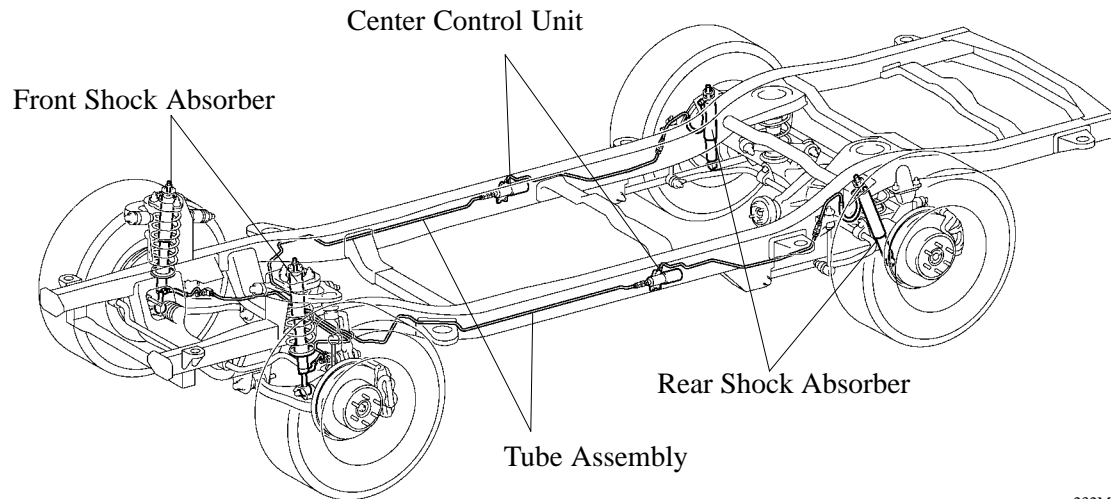

232M054

Rear Air Suspension

- An air suspension that realizes a constant wheel stroke and minimal changes in ride comfort regardless of the number of occupants or the amount of load is available as an option (a set option with the X-REAS on the Limited grade).
- By operating a switch, the driver can set the rear air suspension to three different heights: Normal, HI (+40mm), and LO (-20mm).

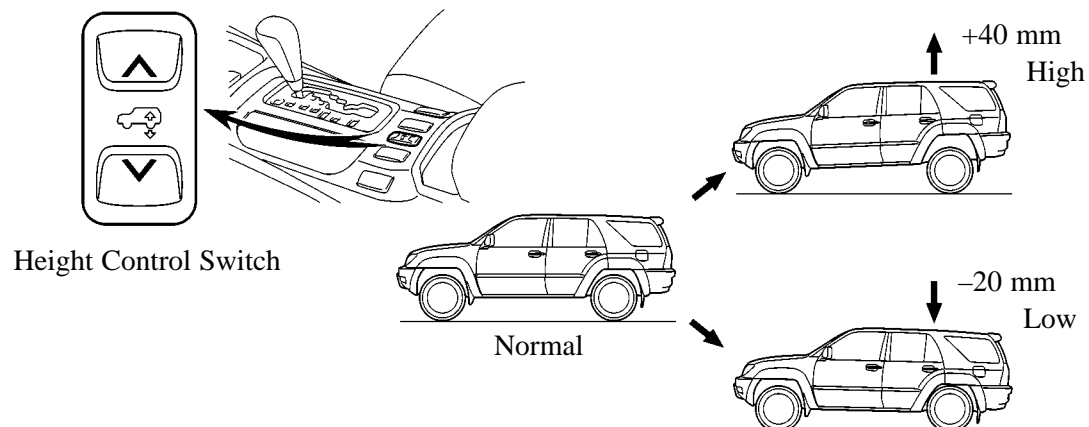

232M055

Brake

- Front and rear ventilated disc brakes have been adopted on the all models.
- A foot pedal type parking brake is provided on all models to improve the ease of use.