

**■ STEERING COLUMN**

- The energy absorbing mechanism mainly consists of a lower bracket, breakaway bracket, energy absorbing plate, main shaft, and column tube.
- When an impact is transmitted to the steering wheel in a collision (secondary collision), the steering wheel and the steering wheel pad help absorb the impact. In addition, the breakaway bracket and the lower bracket separate, causing the entire steering column to move forward. At the time, the energy absorbing plate becomes deformed to help absorb the impact of the secondary collision.
- Two types of steering columns are available for the '03 4Runner: with tilt mechanism and with tilt and telescopic mechanism.
- With the tilt adjustment range of 15° (3° × 5 steps) and the telescopic adjustment range of 45 mm (1.77 in.), the steering column can be adjusted to a position selected by the driver.
- An aluminum made main shaft has been adopted to reduce the weight.

**► Energy Absorbing Mechanism ◀**

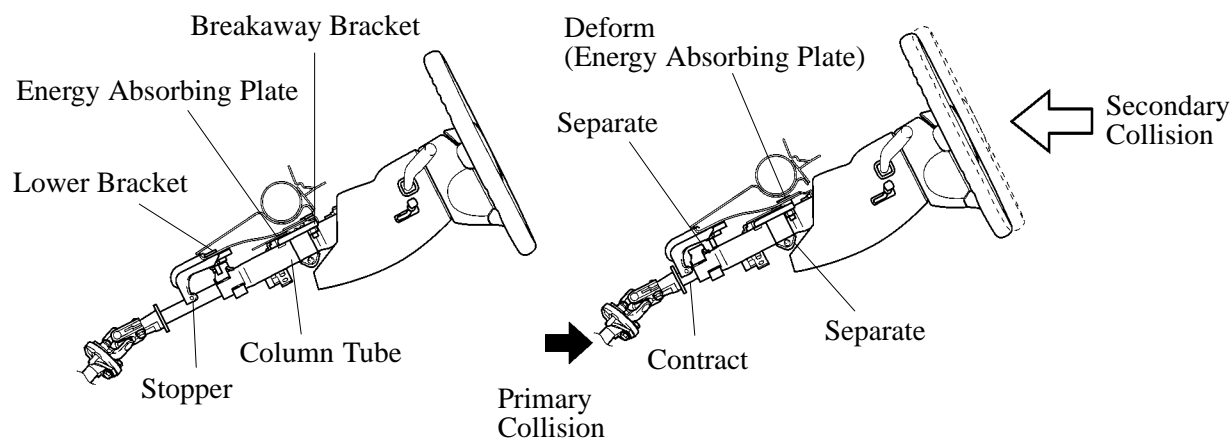

**► with Tilt ◀**

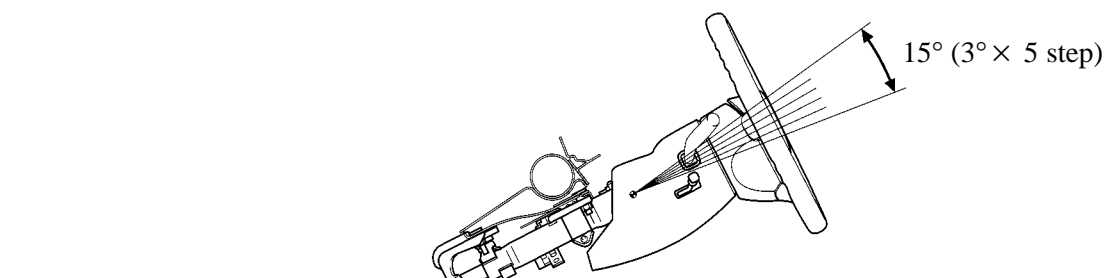

**► with Tilt and Telescopic ◀**

