

## 4. Rear Air Suspension

### General

- This system uses pneumatic cylinders instead of the coil springs that are used in a conventional rear suspension. The suspension control ECU analyzes the information based on the switches, sensors, and input signals, operates the compressor & motor with dryer, and uses the solenoid valves to control the vehicle height.
- The suspension control ECU detects, via the 2 height control sensors, the changes in the rear vehicle height that results from the number of occupants or the amount of the load. Then, the suspension control ECU controls the height control solenoid valves and the compressor & motor with dryer in order to automatically adjust the rear vehicle height to a constant (normal) vehicle height.
- Furthermore, three vehicle heights can be selected by operating the height control switch: HI, Normal, and LO. The HI vehicle height ensures the vehicle's drive-through performance on rough roads. The LO vehicle height facilitates the entry and exit of the occupants and the loading and unloading of cargo. The Normal vehicle height helps realize excellent controllability and riding comfort during normal driving.

### ► System Diagram ◀

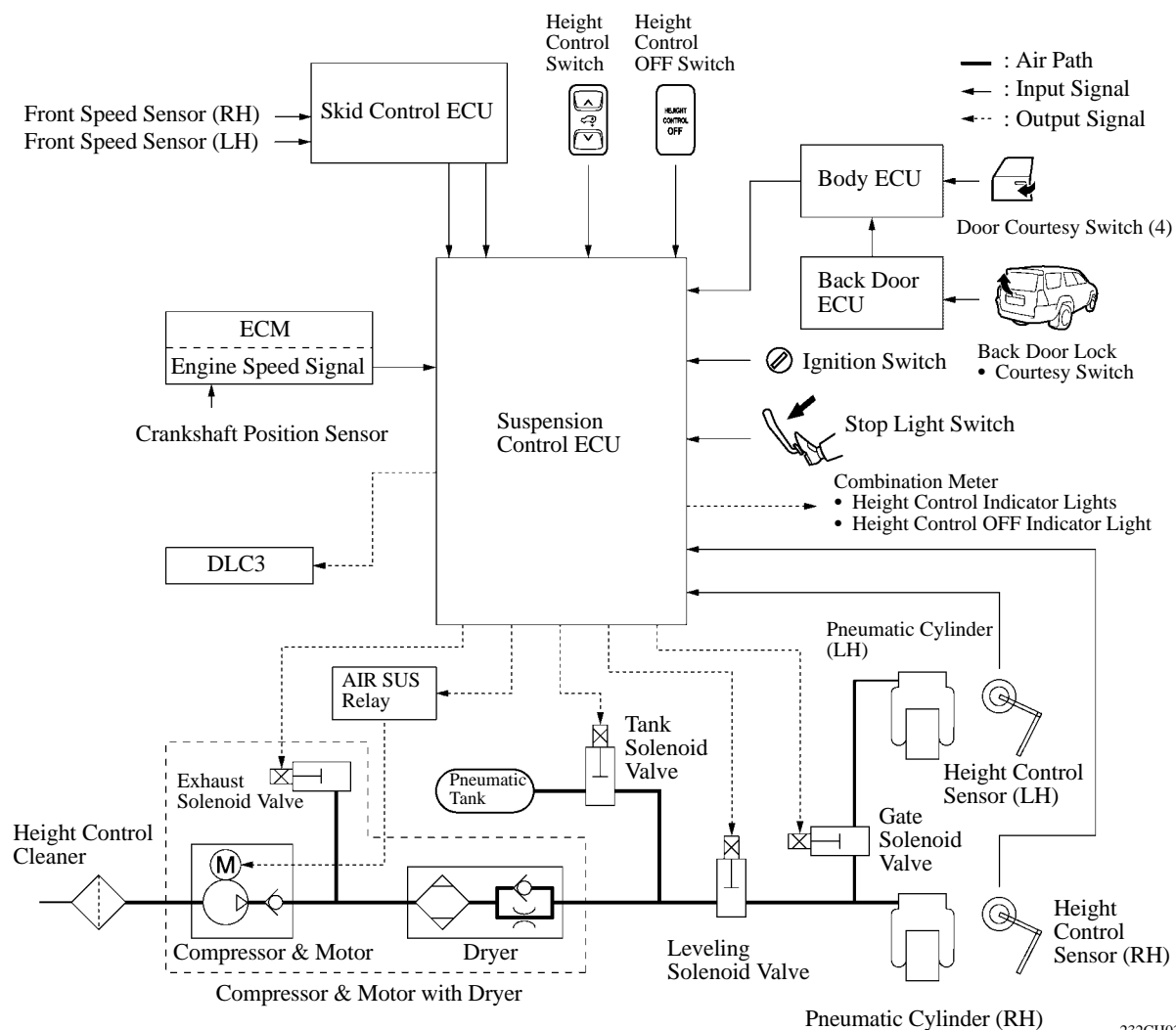

### CAUTION

Before raising the rear air suspension on a jack, make sure to press the height control OFF switch to prohibit height control.

Layout of Main Component

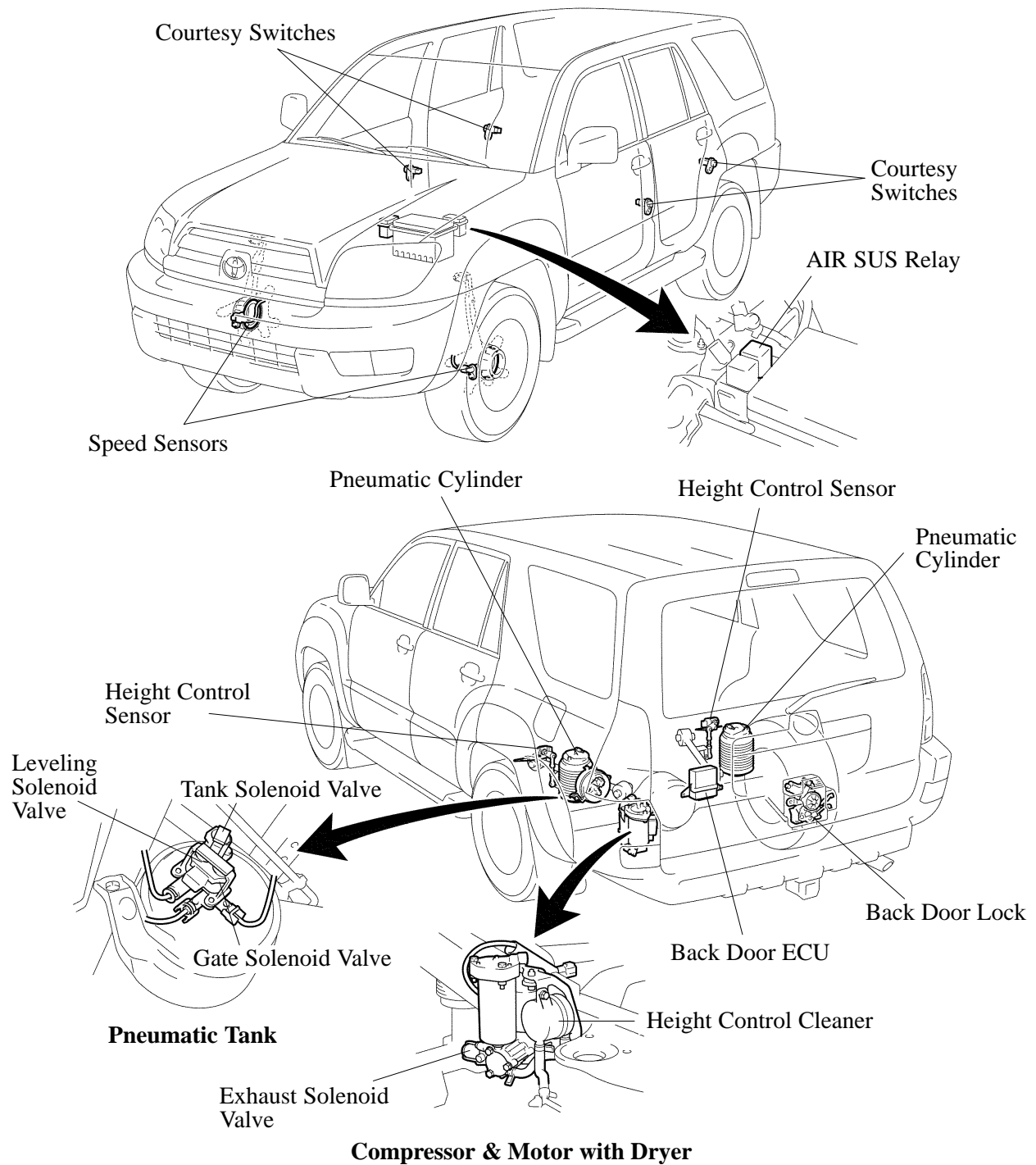

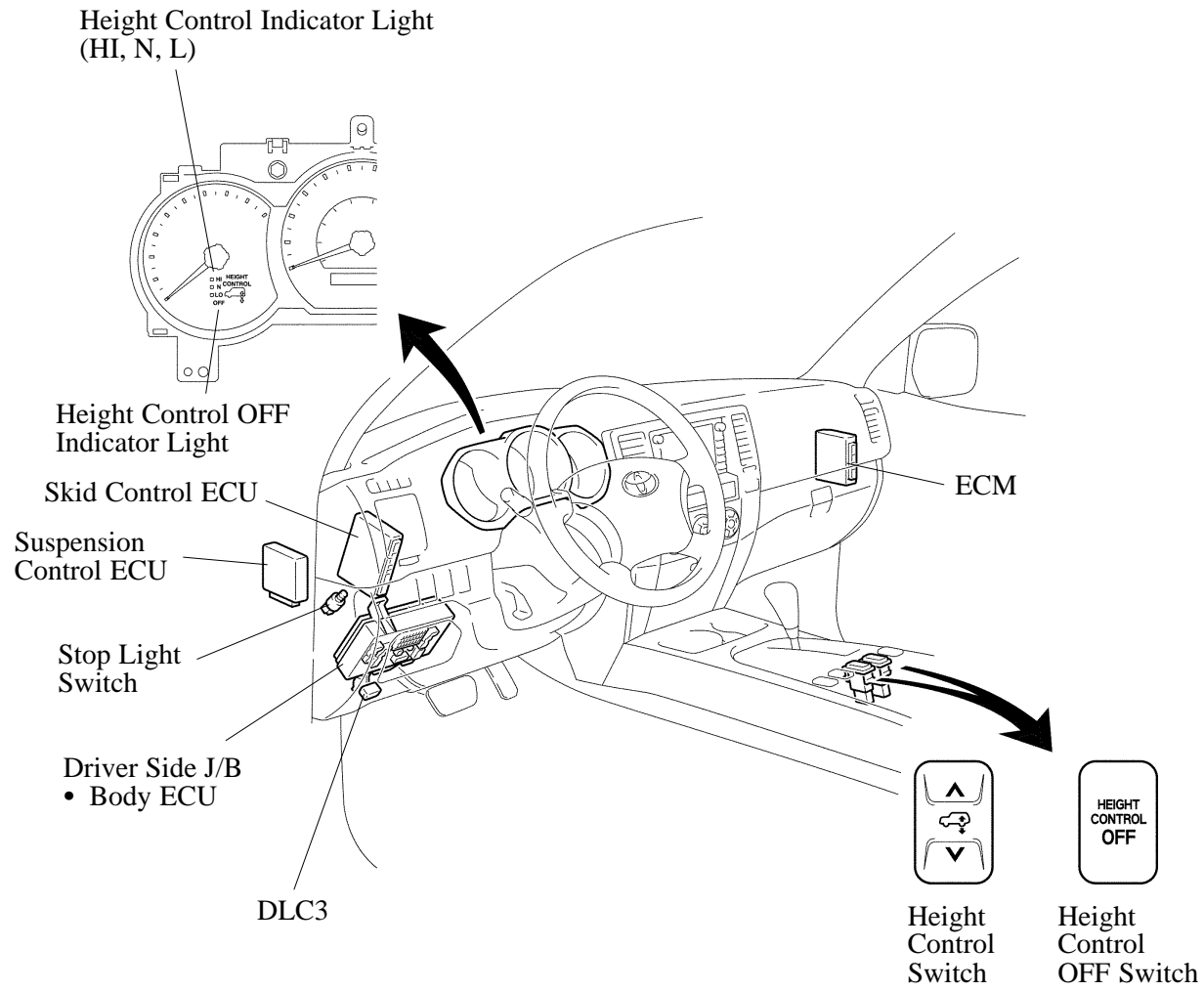

Wiring Diagram

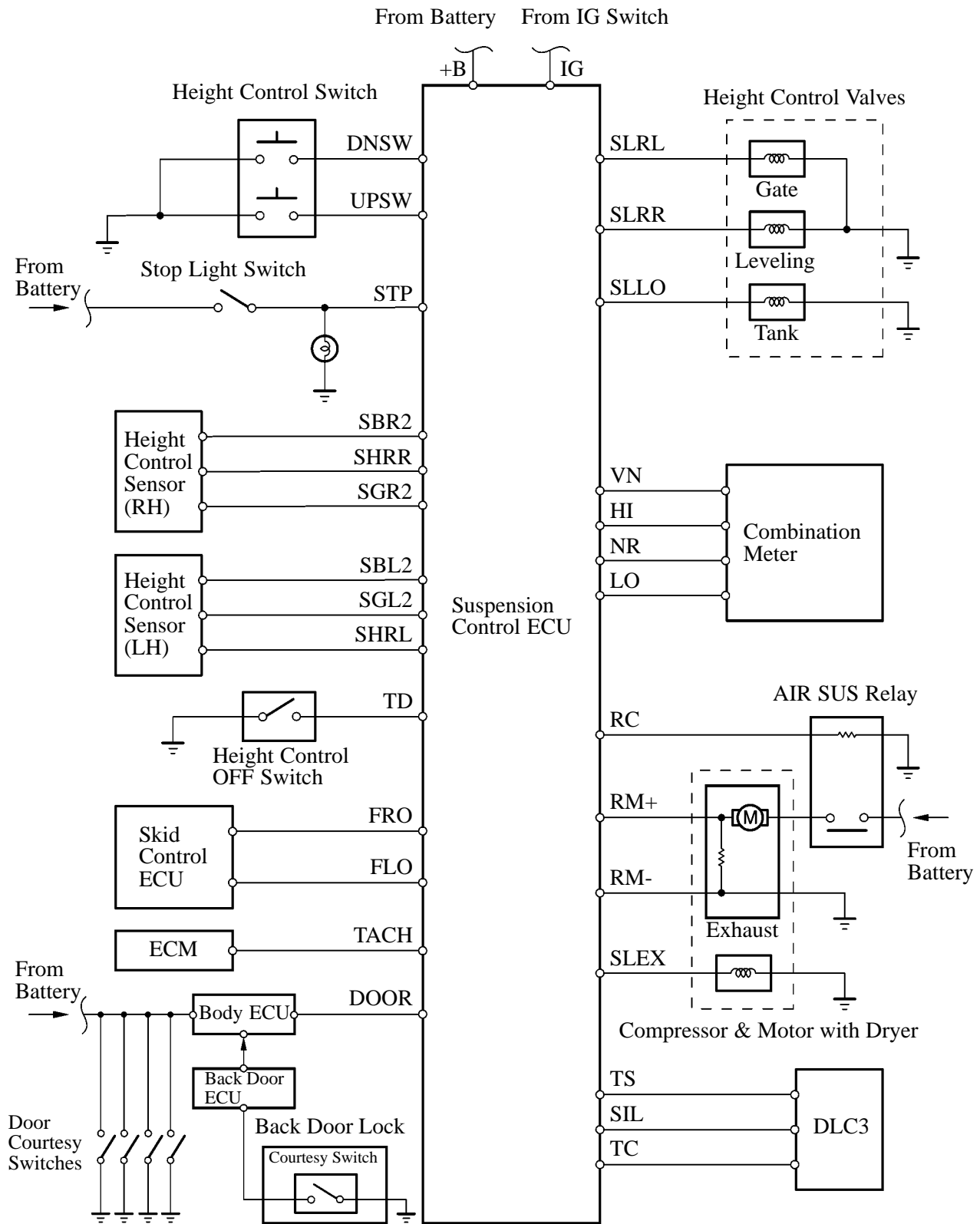

## Air Suspension Tubing Diagram

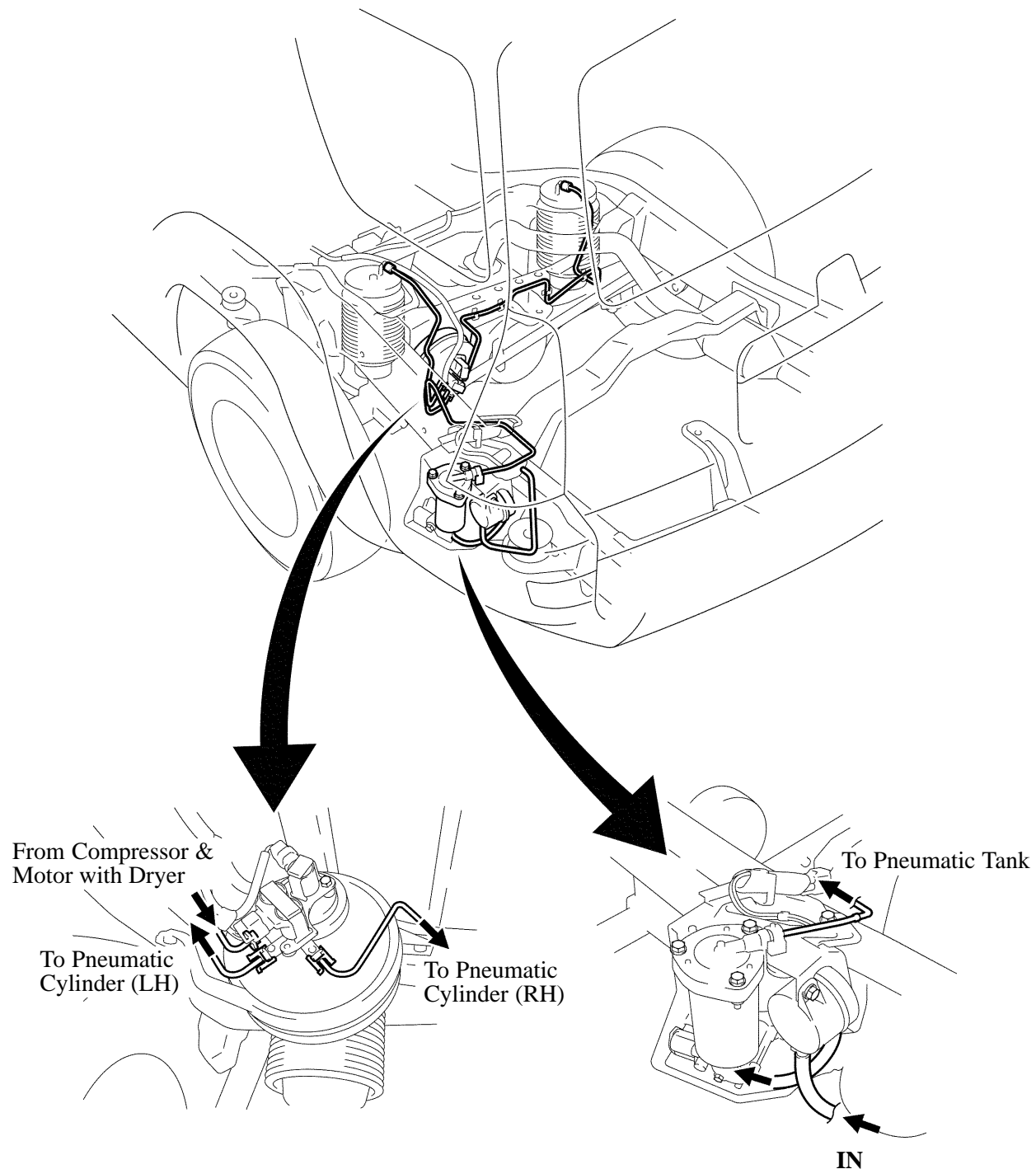

232CH02

**Service Tip**

Quick joints are used for connecting the air suspension tubes. As a result, the ease of operation and service has been ensured. Make sure to use the SST (09730-00010) to disconnect the joints. For details, see the 2003 4Runner Repair Manual (Pub. No. RM1001U).

**Function of Component**

Component		Function
Compressor & Motor with Dryer		<ul style="list-style-type: none"> <li>Supplies compressed air to increase the vehicle height.</li> <li>Removes moisture in the compressed air.</li> </ul>
	Exhaust Solenoid Valve	Discharges compressed air to atmosphere from pneumatic cylinder to lower the vehicle.
Height Control Cleaner		Removes dust and sand from the internal air.
Height Control Switch		Selects the target vehicle height.
Height Control OFF Switch		Prohibits the adjustment of the vehicle height.
Combination Meter	Height Control Indicator Light (3)	Indicates the present vehicle height condition (HI, Normal, LO).
	Height Control OFF Indicator Light	<ul style="list-style-type: none"> <li>Lights to inform the driver when the height control is turned OFF by the height control OFF switch.</li> <li>Blinks to alert the driver when the suspension control ECU detects the malfunction in the rear air suspension.</li> <li>Indicate the DTCs (Diagnostic Trouble Codes) of the rear air suspension.</li> </ul>
Pneumatic Cylinder (2)		Supports the vehicle body and adjusts the vehicle height.
Pneumatic Tank		Temporarily stores the exhaust air during the vehicle height down operation.
	Tank Solenoid Valve	Opens/ closes the compressed air path between the pneumatic tank and right and left pneumatic cylinders.
	Leveling Solenoid Valve	Opens/ closes the compressed air path between the compressor and pneumatic cylinder.
	Gate Solenoid Valve	Opens/ closes the compressed air path between the right and left pneumatic cylinder.
Height Control Sensor (2)		Detects the vehicle height (distance between the vehicle body and road surface).
Stop Light Switch		Detects the brake pedal depressed to clear the DTC.
Door Courtesy Switch (4)		Detects the open/ close condition of the doors.
Body ECU		Receives the signals of the 4 door courtesy switches and the back door ECU and sends it to the suspension control ECU.
Back Door Lock	Courtesy Switch	Detects the open/ close condition of the back door.
Back Door ECU		Receives the signals of the courtesy switch in the back door lock and sends it to the body ECU.
AIR SUS Relay		Supply the electricity to the compressor & motor with dryer.
Suspension Control ECU		<ul style="list-style-type: none"> <li>Controls the vehicle height according to the operation modes.</li> <li>Blinks the height control OFF indicator light to alert the driver when the suspension control ECU detects a malfunction in the rear air suspension.</li> <li>Blinks the height control OFF indicator light to output the DTCs (Diagnostic Trouble Codes) of the rear air suspension.</li> </ul>

## Construction and Operation of Main Component

### 1) Compressor & Motor with Dryer

- The compressor and motor are used to make the compressed air necessary for raising the vehicle height.  
An exhaust solenoid valve is provided on the compressor & motor. The exhaust solenoid valve discharges compressed air from the pneumatic cylinders to the atmosphere in order to lower the vehicle.
- To protect the battery, this compressor & motor with dryer operates only when the engine is running.
- The dryer is used to eliminate the moisture in the compressed air made by the compressor and motor, and the exhaust valve to drain the compressed air out to the atmosphere from the pneumatic cylinders.

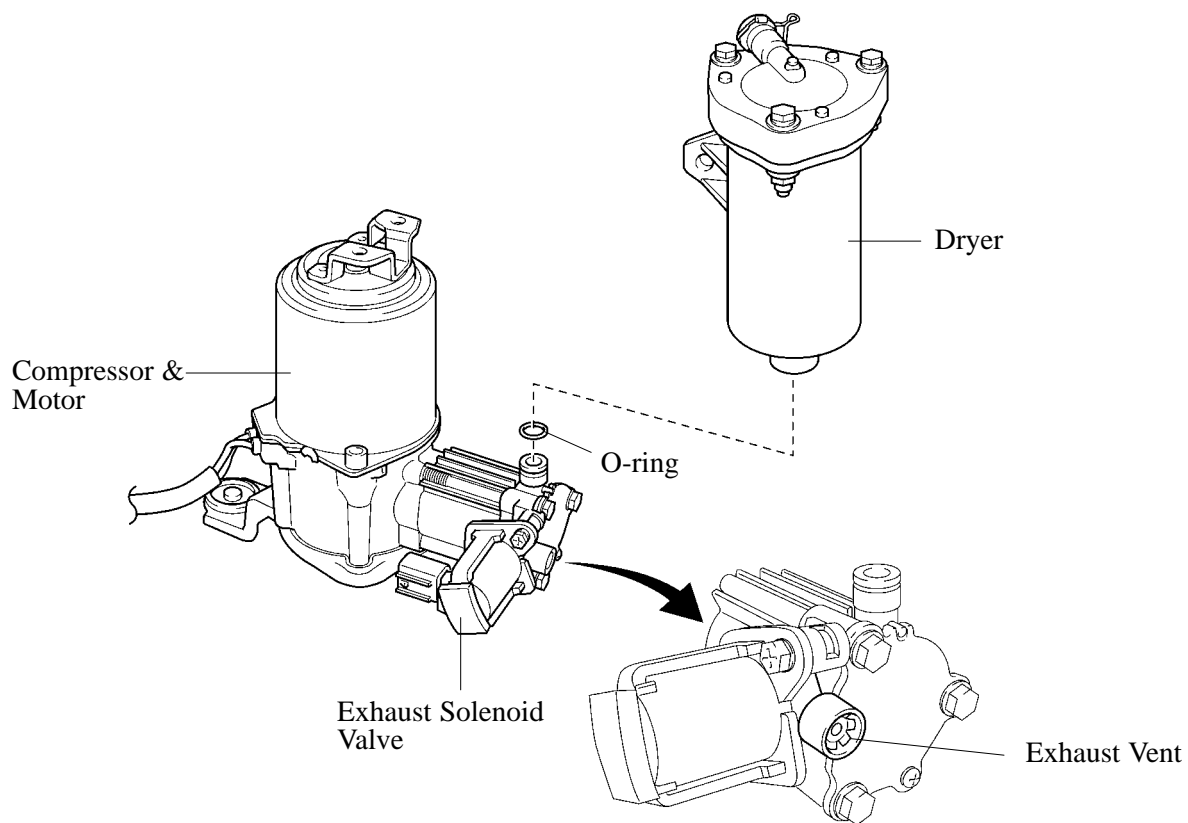

232CH146

### ► Specification ◀

Motor	Type	DC
	Rated Voltage	12 V
Exhaust Solenoid Valve	Rated Voltage	12 V
	Operating Voltage Range	10 – 15 V
	Resistance	10 – 14 $\Omega$

## 2) Height Control Cleaner

- The height control cleaner consists of a filter to remove dust and debris, and an expansion chamber to reduce the intake sound. In consideration of dusty areas, this cleaner draws air from the inside of the vehicle cabin.
- This cleaner cannot be disassembled; therefore, it is not possible to replace only the filter element.

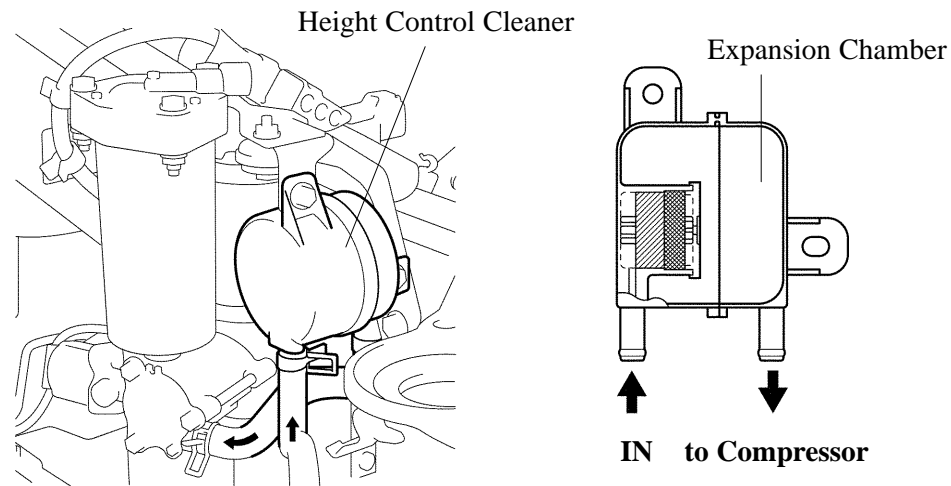

232CH137

## 3) Pneumatic Cylinder

Pneumatic cylinder consists of a single type air chamber with a large compressed air capacity in order to realize excellent riding comfort.

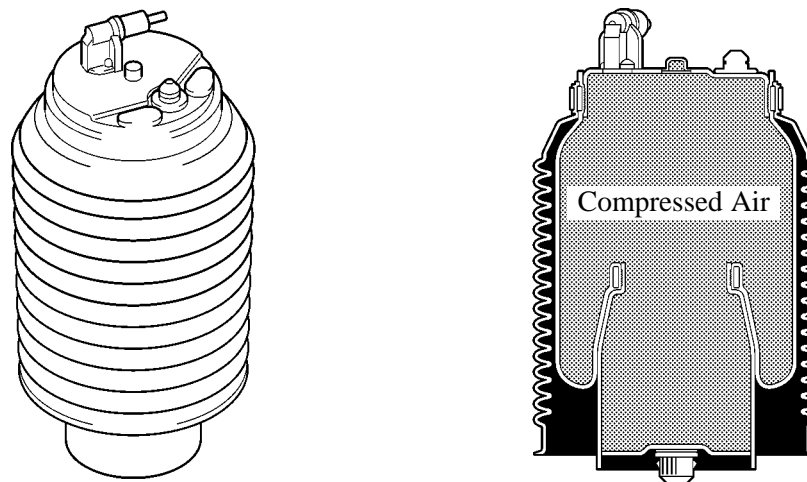

232CH16

### Service Tip

To remove a pneumatic cylinder, perform the operation by supporting the frame, raising the rear axle on a jack, and leaving the shock absorbers attached in place.  
For details, see the 2003 4Runner Repair Manual (Pub. No. RM1001U).

4) Pneumatic Tank

- The pneumatic tank, which temporarily stores the exhaust air from the pneumatic cylinders, contributes in reducing the length of time that is required for lowering the vehicle height.
- The height control valve consists of a leveling solenoid valve, gate solenoid valve, and tank solenoid valve.

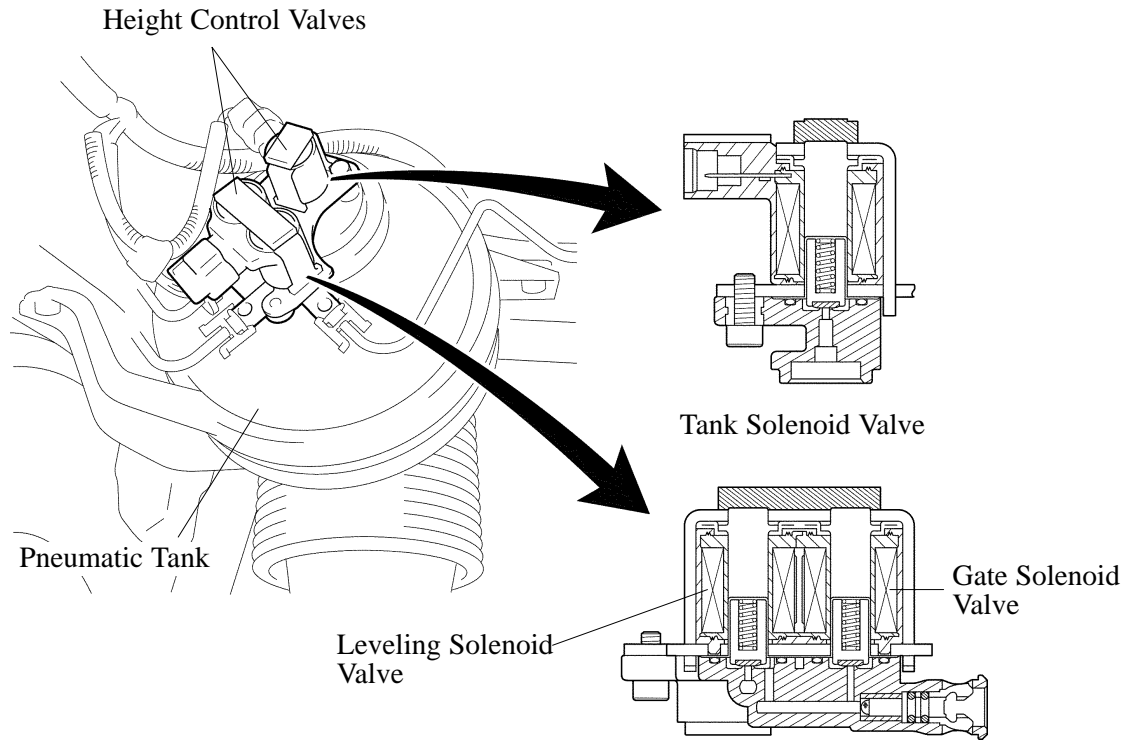

232CH98

► Specification ◀

Height Control Valve	Leveling & Tank Solenoid Valve	Rated Voltage	12 V
		Operating Voltage Range	10 – 15 V
		Resistance	10 – 14 Ω
	Gate Solenoid Valve	Rated Voltage	12 V
		Operating Voltage Range	10 – 15 V
		Resistance	17.5 – 21.5 Ω

### 5) Height Control Sensor

The height control sensors detect the vehicle's height. There are two rear height control sensors, one for the right, and the other for the left. This sensor consists of a brush that is integrated with a shaft, which slides on the resistor that is formed on a substrate. Because the resistance value between the brush and the resistor terminal varies in proportion to the shaft's rotational angle, a prescribed amount of voltage is applied to the resistor so that a change in the rotational angle can be detected in the form of a voltage change.

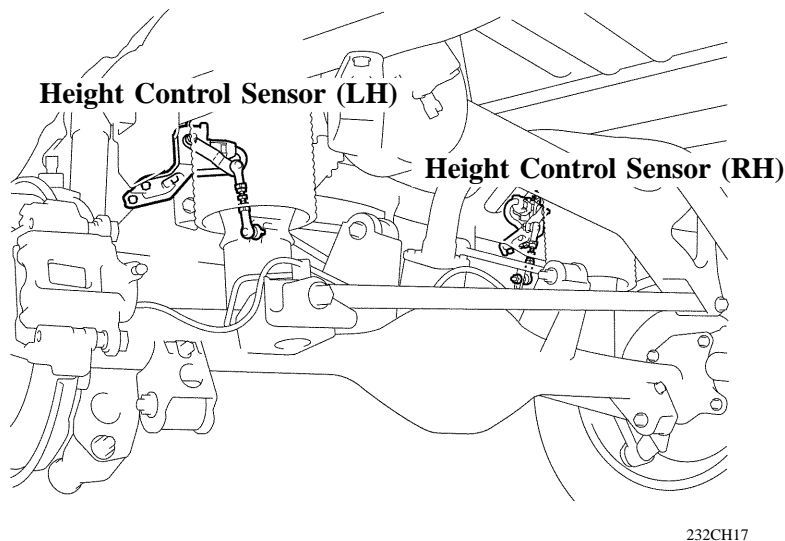

232CH17

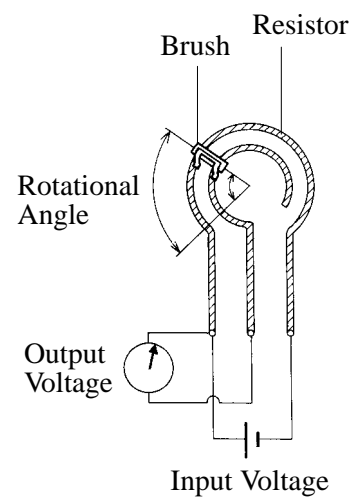

155CH41

#### Diagram of the Principle

#### Service Tip

Refer to the following factors when adjusting the link of the height control sensor:

- Vehicle height will be changed approximately 3 mm (0.12 in.) if moving both link installation positions approximately 1 mm (0.04 in.) simultaneously.
- Vehicle height will be changed approximately 6 mm (0.24 in.) if rotating both links once simultaneously.

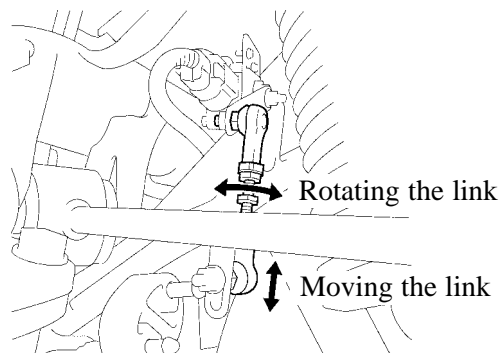

232CH18

## System Operation

### 1) General

This system operation effects the following controls:

System Operation		Outline
Initial Control		To initialize the system, this control is effected each time the ignition switch is turned ON.
Reflash Control		Eliminates the difference in the compressed air pressure between the right and left pneumatic cylinders.
Exhaust Control		Automatically exhausts the compressed air that is temporarily stored in the pneumatic tank during the vehicle height down operation.
Vehicle Height Control	Automatic Height Control	Maintains a constant rear vehicle height regardless of the number of occupants or the amount of load.
	Vehicle Height Switching	The vehicle height (HI, Normal, or LO) can be set as desired by the driver by operating the height control switch.
	Vehicle Speed Sensing	Even if the vehicle height is set to HI or LO by the height control switch, this function automatically resumes to the normal vehicle height if the vehicle speed is higher than a prescribed speed [LO: 12 km/h (7 mph), HI: 30 km/h (19 mph)].
	Key OFF Operation	If an occupant exits the vehicle when the ignition key is OFF, causing the vehicle height to rise, this function corrects the vehicle height by lowering it for a prescribed length of time.
	Vehicle Height Control OFF	Pressing the height control OFF switch prohibits height control.
Suspension Control	Normal Control	Shuts off the right and left pneumatic cylinders by closing the gate solenoid valve, in order to ensure the proper rolling rigidity.
	Off-road Control	Connects the right and left pneumatic cylinders by opening the gate solenoid valve, in order to ensure the proper drive-through performance on very bumpy roads.
Diagnosis		When the suspension control ECU detects a malfunction in this system, it blinks the height control OFF indicator light to inform the driver of the malfunction.

**2) Initial Control**

For approximately 2 seconds after each time the ignition switch is turned ON, the suspension control ECU performs the initial control in accordance with the timing chart shown below. During this control, the suspension control ECU stops all the actuators except the height control motor relay, and illuminates all the indicator lights to check their bulbs.

**► Timing Chart ◀**

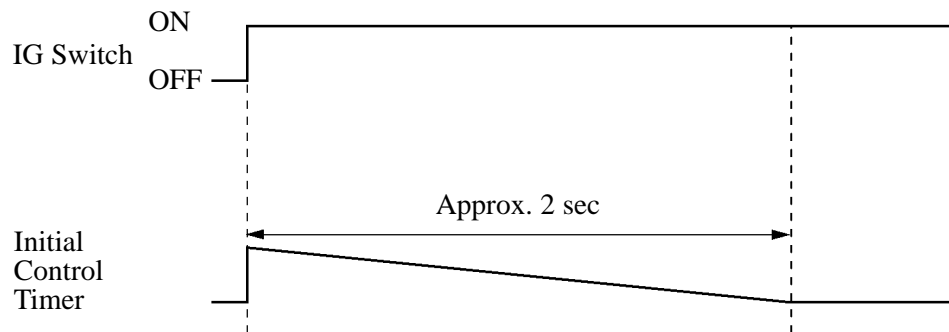

232CH99

**► System Diagram ◀**

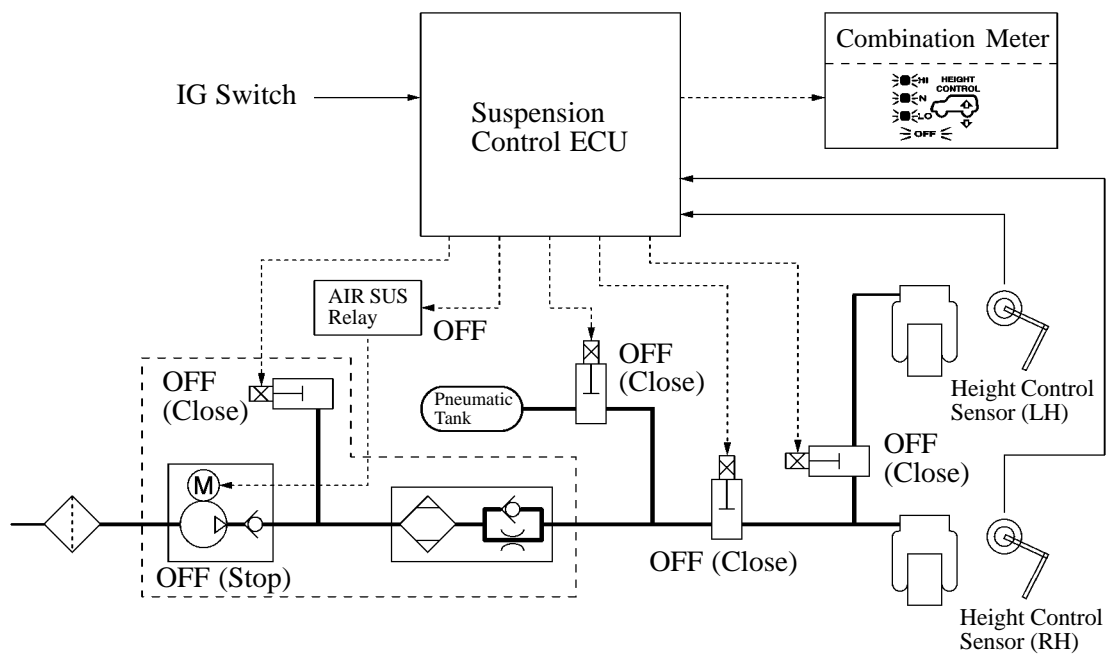

232CH100

**3) Reflash Control**

Reflash control is effected in order to eliminate the difference in the compressed air pressure between the right and left pneumatic cylinders.

From the time the initial control is completed, the suspension control ECU turns ON (open) the gate solenoid valve in accordance with the timing chart shown below, in order to connect the right and pneumatic cylinders.

**► Timing Chart ◀**

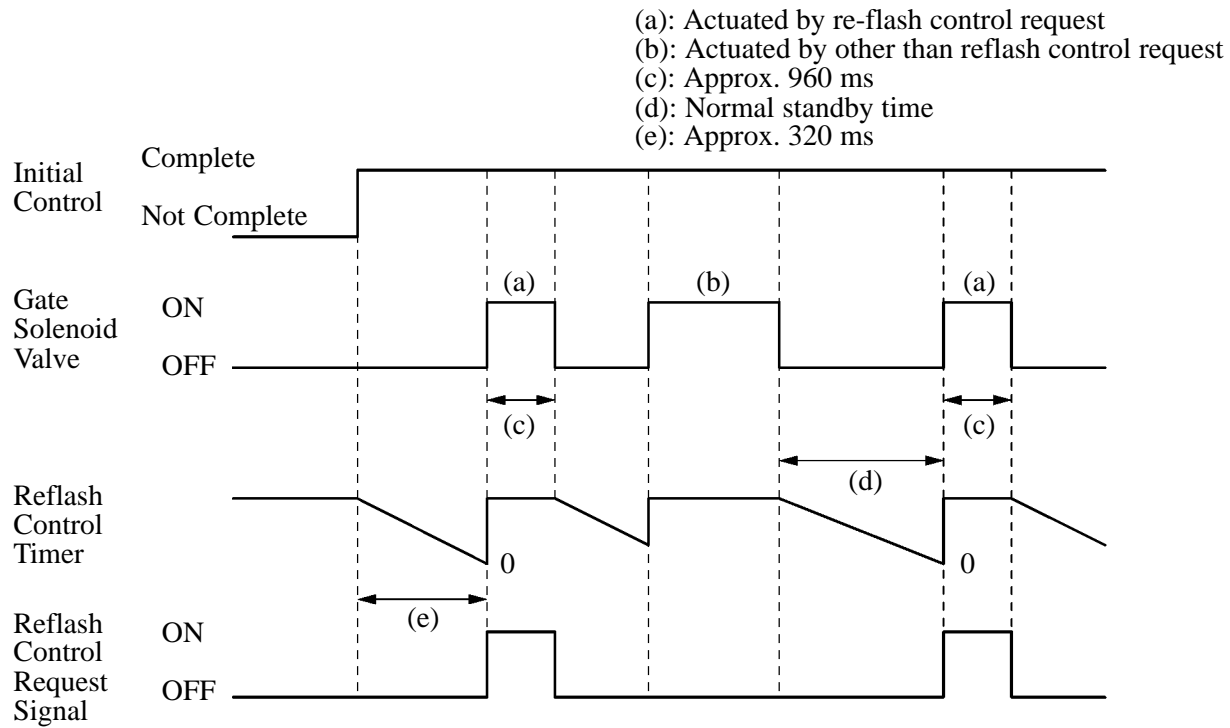

232CH101

**► System Diagram ◀**

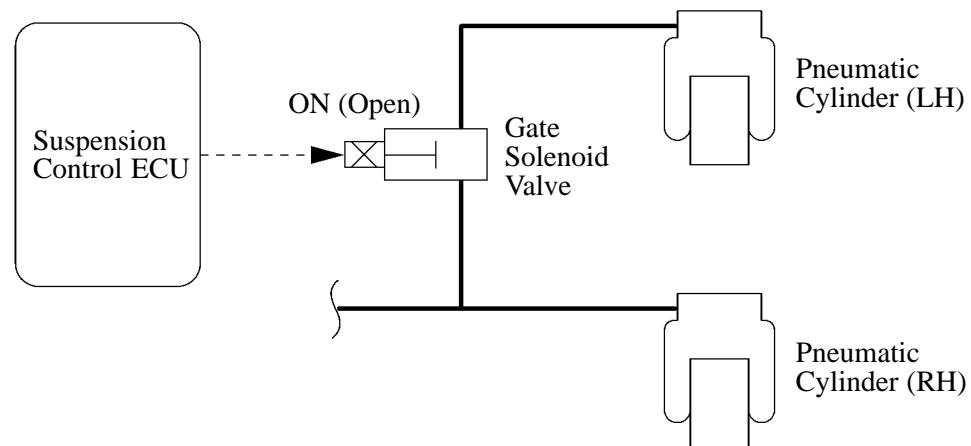

232CH102

#### 4) Exhaust Control

During the height control down operation, this control automatically exhausts the compressed air that is stored in the pneumatic tank

After the completion of the initial control or the height control down operation, the suspension control ECU turns ON (open) the tank solenoid valve and the exhaust solenoid valve in accordance with the timing chart shown below, in order to exhaust the compressed air from the pneumatic tank.

##### ► Timing Chart ◀

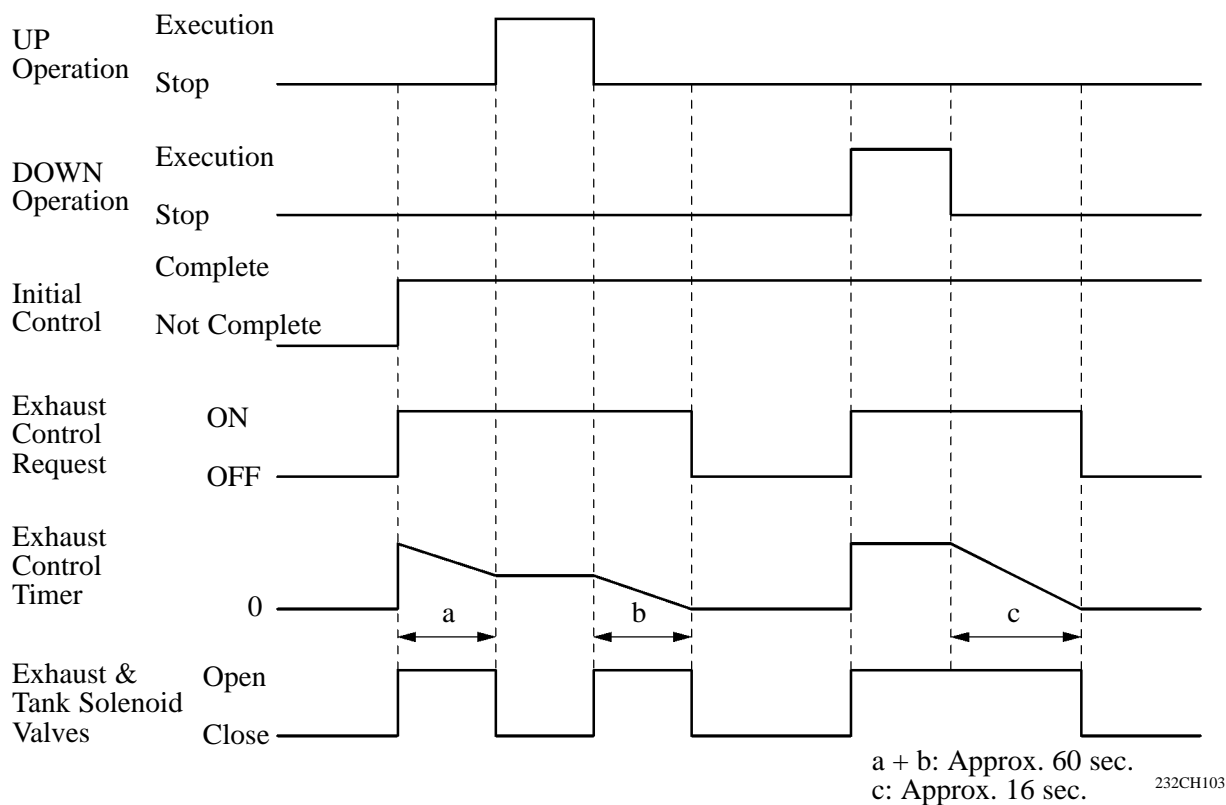

##### ► System Diagram ◀

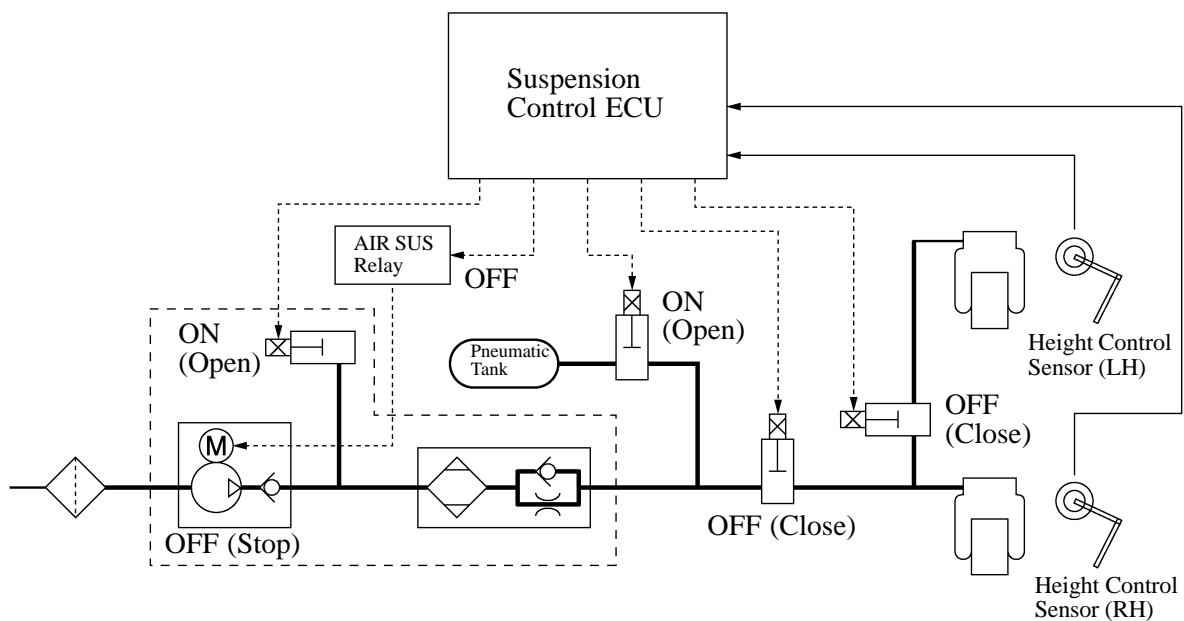



- If the vehicle height is higher than normal, the suspension control ECU lowers the vehicle height by turning ON (open) the exhaust solenoid valve, tank solenoid valve, leveling solenoid valve, and gate solenoid valve, and stopping the compressor & motor with dryer.

► System Diagram ◀

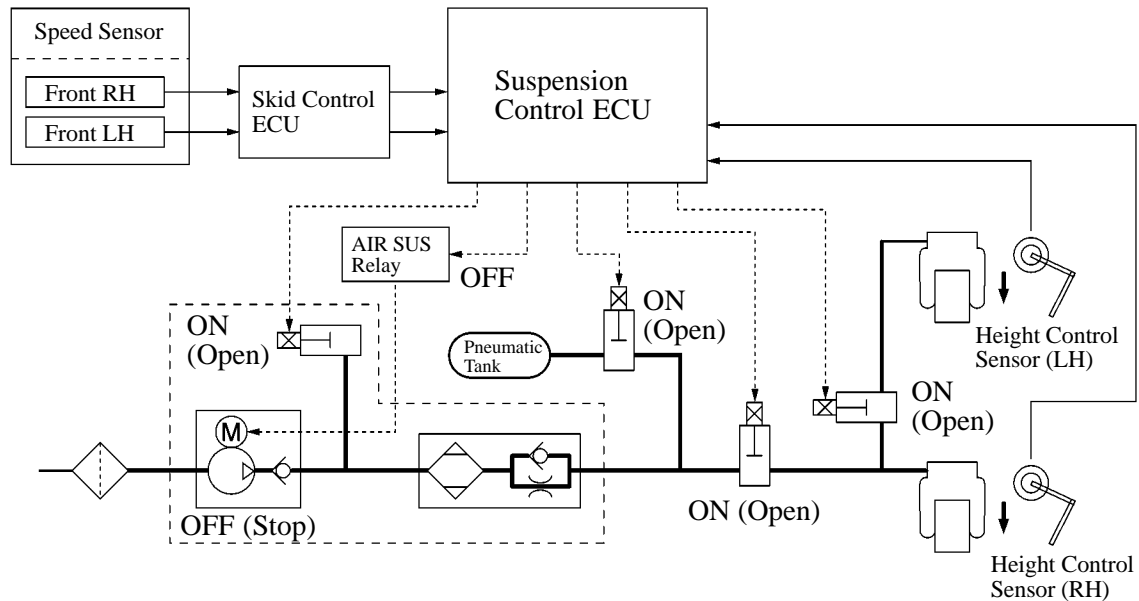

232CH106

**Vehicle Height Switching Control**

Through this control, three vehicle heights (HI, Normal, and LO) can be selected by operating the height control switch within the specified speed ranges.

► Vehicle Speed and Vehicle Height Ranges ◀

Range	Select Vehicle Height	Specification
Vehicle Speed	Normal → HI	30 km/h (19 mph) lower
	Normal → LO	12 km/h (7 mph) lower
Vehicle Height	HI	+40 mm (1.6 in.)/ Approx. 15 – 20 sec.
	Normal	0
	LO	-20 mm (0.8 in.)/ Approx. 10 – 15 sec.

- The suspension control ECU detects the vehicle speed through the signals from the front speed sensors and the target vehicle height through the signals from the height select switch. When these signals meet the operation conditions, the suspension control ECU performs the vehicle height UP/ DOWN operation.
- Upon detecting the changes in the vehicle height through the signals from the height control sensors, the suspension control ECU blinks the selected vehicle height indicator light during the switching operation, and illuminates it after the operation has been completed.

► Height Control Switch: Normal → HI ◀

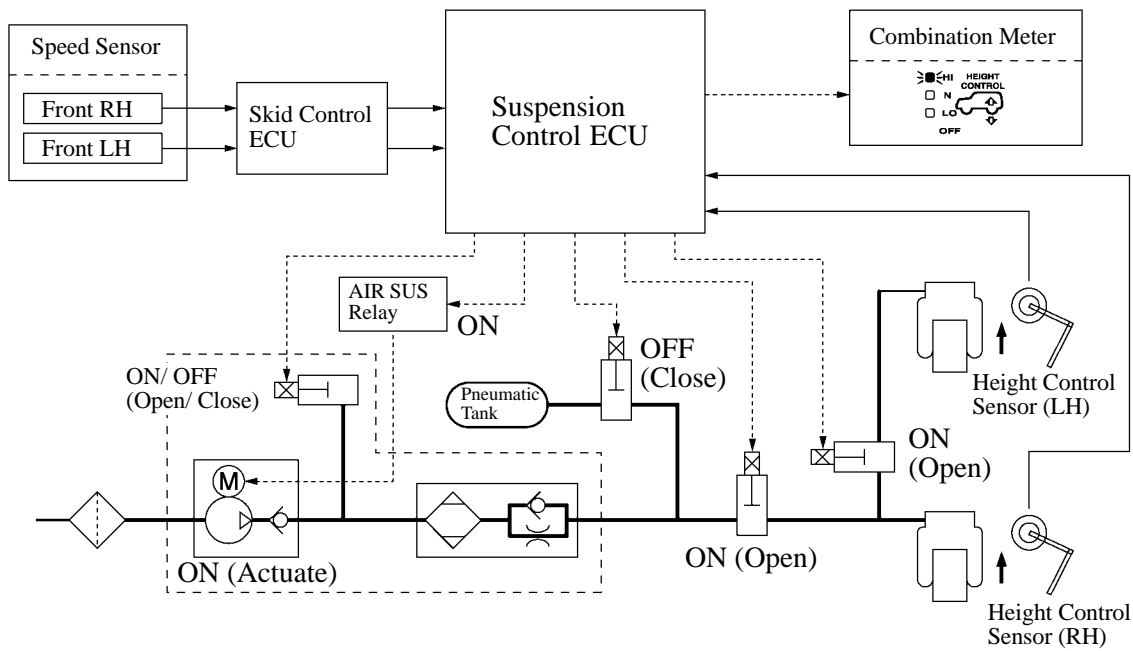

232CH107

► Height Control Switch: Normal → LO ◀

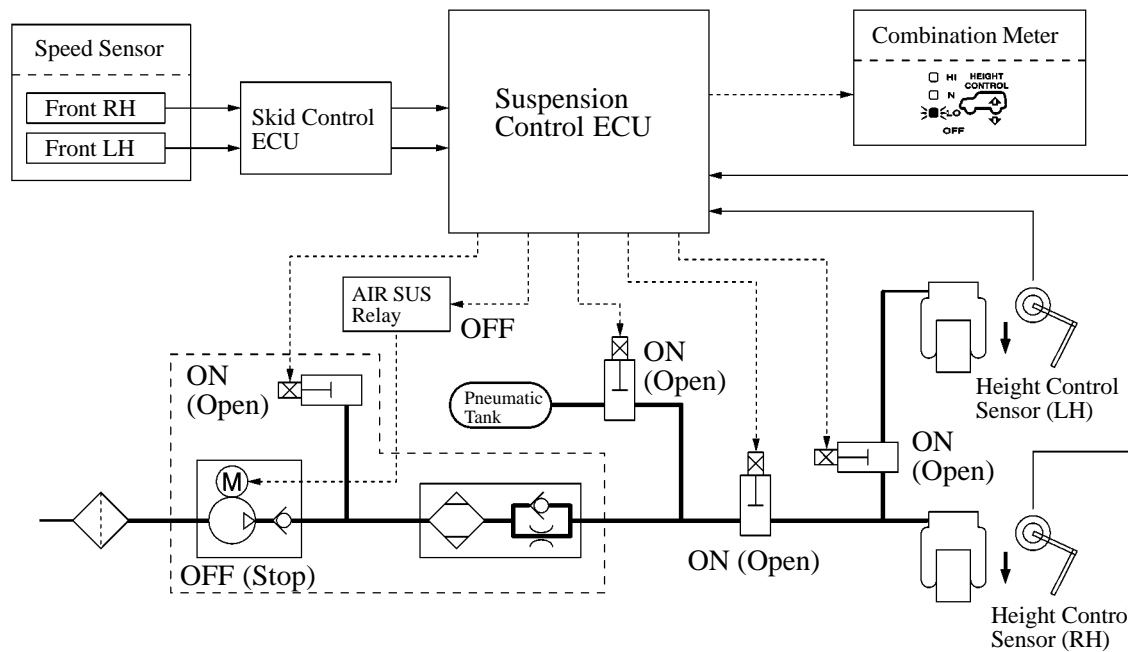

232CH108

**Vehicle Speed Sensing Control**

- The suspension control ECU detects the vehicle speed through the signals from the front speed sensors. When the vehicle reaches a prescribed vehicle speed or higher, this control resumes the normal vehicle height regardless of the height control switch. At this time, the suspension control ECU blinks the height control indicator (for normal) and illuminates it after height control has been completed.

▶ **Resume Vehicle Speed** ◀

Item	Vehicle Height	Specification
Vehicle Speed	HI → Normal	30 km/h (19 mph) or more
	LO → Normal	12 km/h (7 mph) or more

- Once the vehicle resumes its normal vehicle height through this control, it is not possible to select a vehicle height by operating the height control switch at a prescribed vehicle speed or below, unless the initial control is effected again.

▶ **Vehicle Height: HI → Normal** ◀

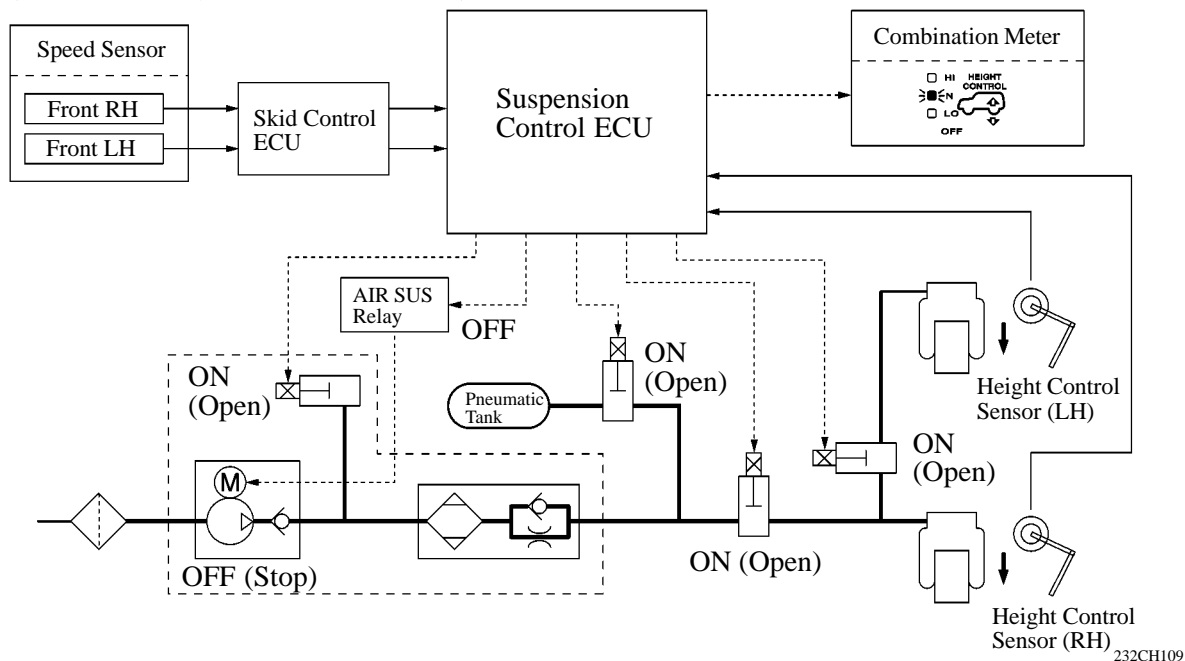

▶ **Vehicle Height: LO → Normal** ◀

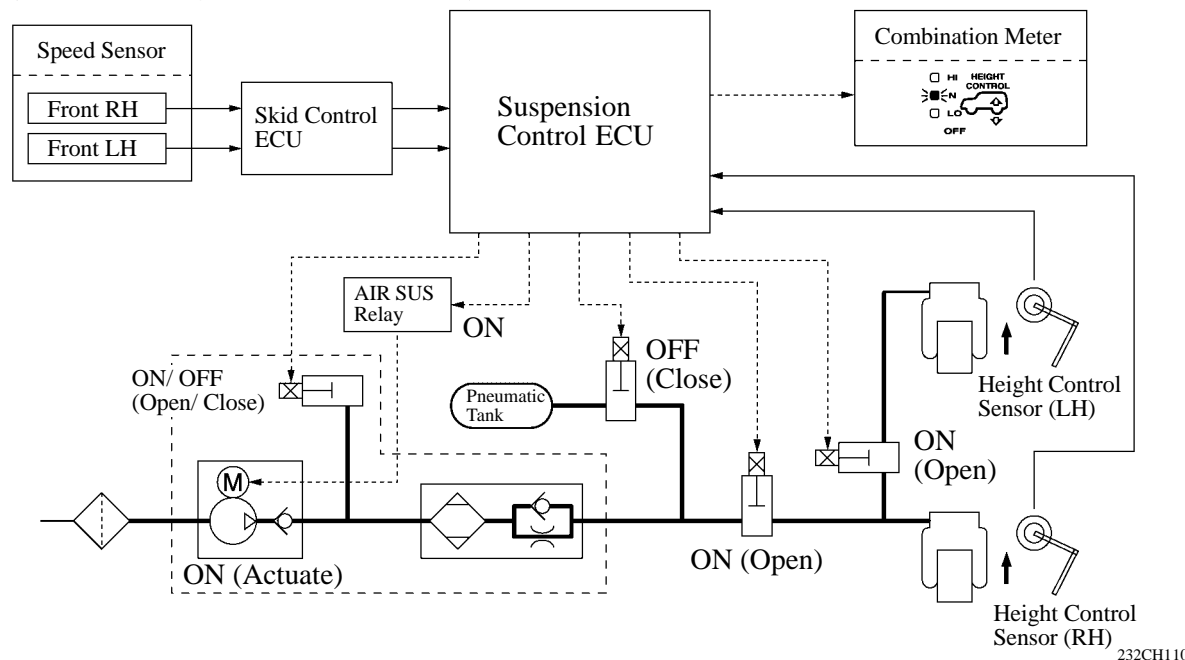

**Key OFF Operation Control**

If an occupant exits the vehicle or a cargo is unloaded when the ignition key is OFF, causing the vehicle height to rise, this control causes the vehicle to resume the target vehicle height only for a prescribed length of time.

- The suspension control ECU detects the OFF signal through the ignition switch, the door open/close signal from the 5 door courtesy light switches, and the vehicle height condition from the 2 height control sensors, in order to effect the key OFF operation control in accordance with the timing chart.
- There are 2 key OFF operation times depending on the vehicle height condition.

Vehicle Height Condition	Key OFF Operation Time
No change	Approx. 15 sec.
Change	Approx. 25 sec.

► **Timing Chart** ◀

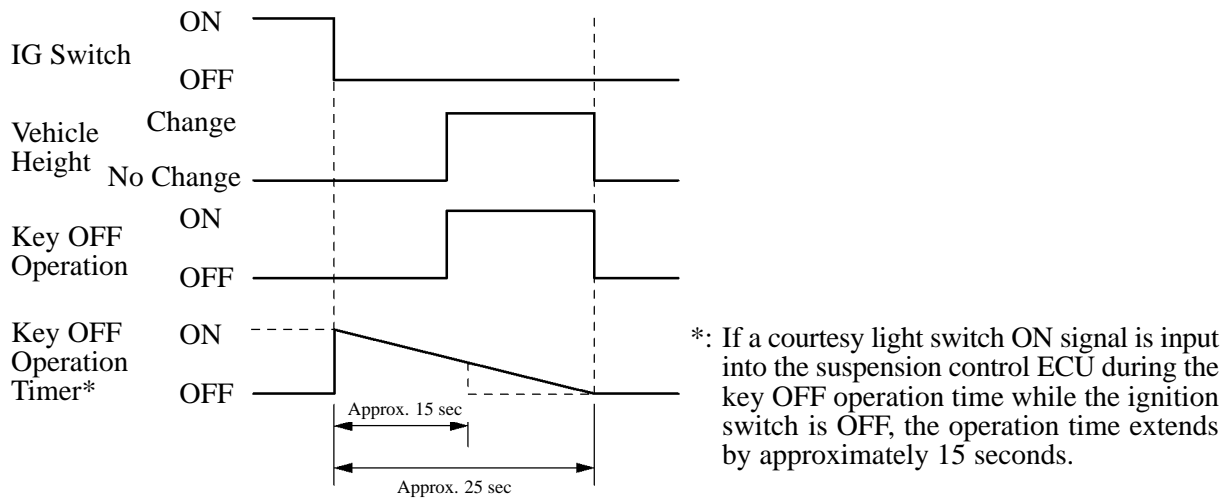

232CH111

► **System Diagram** ◀

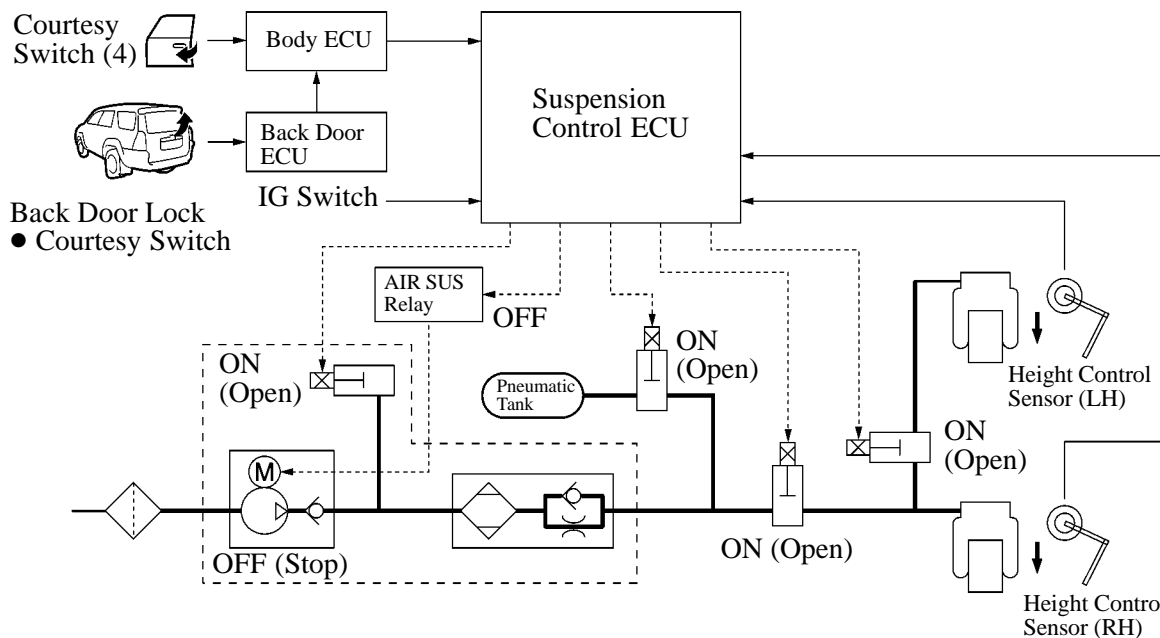

232CH112

**Vehicle Height Control OFF Control**

When the height control OFF switch is pressed, this control prohibits vehicle height control at a vehicle speed sensing range.

The suspension control ECU prohibits height control in accordance with the signals from the height control OFF switch and illuminates the height control OFF indicator light.

When the vehicle exceeds the vehicle speed 30 km/h (19 mph), this control releases to ensure safety and turns OFF the height control OFF indicator light.

► **System Diagram** ◀

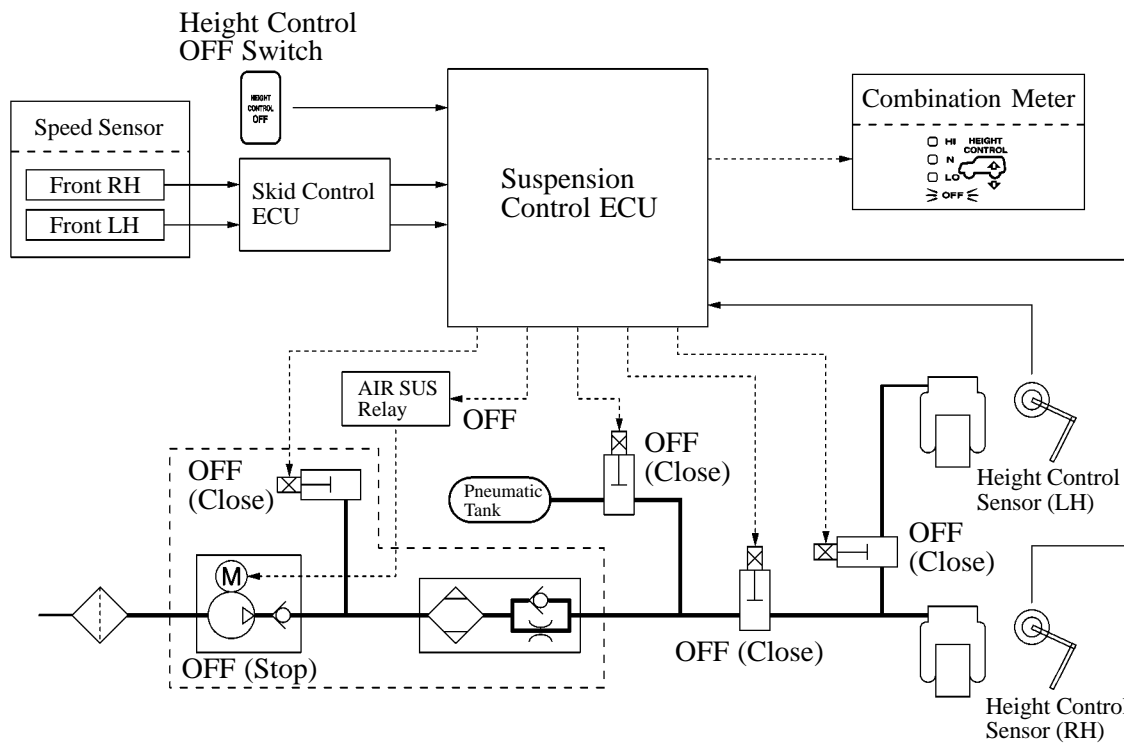

**6) Suspension Control**

**General**

Suspension control consists of a normal control and off-road control.

- The normal control turns OFF (close) the gate solenoid valve during normal driving, in order to increase the vehicle’s rolling rigidity.
- The off-road control turns ON (open) the gate solenoid valve while the vehicle is being driven on bumpy roads at low speeds, in order to ensure the proper drive-through performance.

**Normal Control**

Upon detecting the vehicle speed through the signals from the right and left front speed sensors, and the vehicle height through the signals from the right and left height control sensors, the suspension control ECU turns OFF (close) the gate solenoid valve in order to shut off the air path between the right and left pneumatic cylinders.

**► System Diagram ◀**

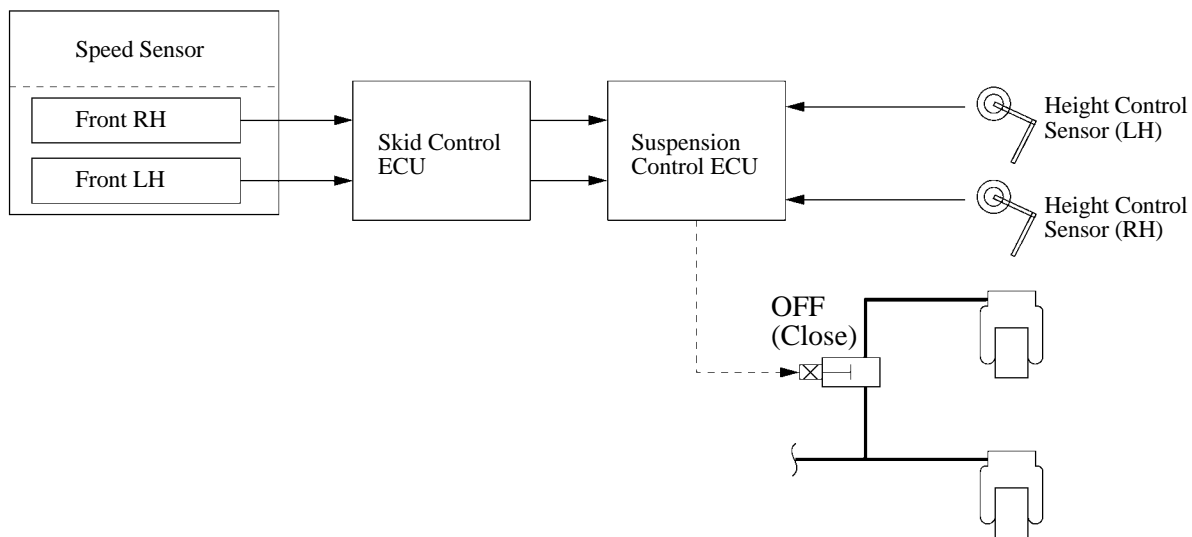

**Off-road Control**

- The skid control ECU detects the vehicle speed and the speed difference between the right and left wheels through the signals from the right and left front speed sensors, and the difference between the right and left vehicle height through the signals from the right and left height control sensor.
- When all of these signals have reached the following tables, the suspension control ECU turns ON (open) the gate solenoid valve to connect the right and left pneumatic cylinders.

► **Set Operation Conditions** ◀

Vehicle Speed	Approx. 20 km/h (12 mph) less than
Wheel Speed Difference	Approx. 5 km/h (3 mph) more than
Vehicle Height Difference	Approx. 100 mm (3.93 in.) more than

► **System Diagram** ◀

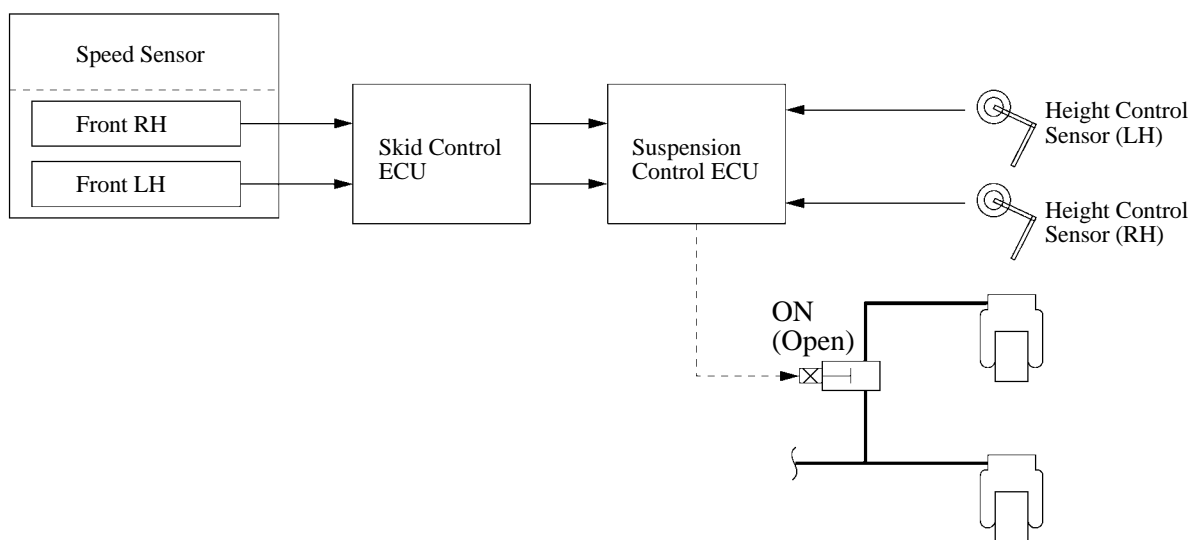

232CH115

- A timer is provided to clear this control in order to prevent hunting.

\* See the set operation condition table

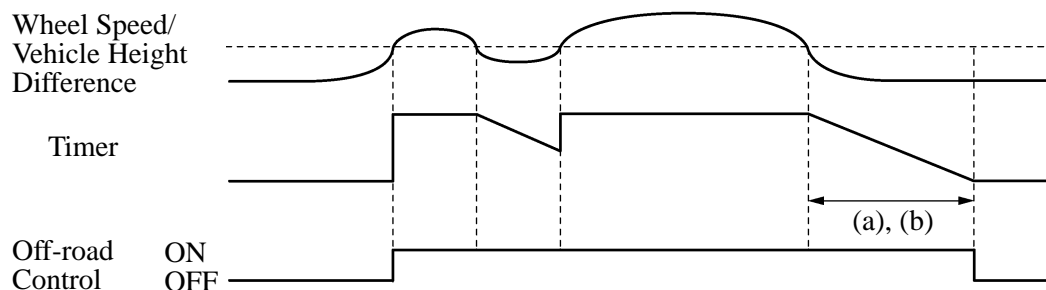

(a): for Wheel Speed Timer/ Approx. 2 sec.  
 (b): for Vehicle Height Timer/ Approx. 1 sec.

232CH144

## 7) Diagnosis

Diagnosis function has a DTC output, input signal check (test mode), active test, and fail- safe. If the suspension control ECU detects a malfunction in this system, it blinks the height control OFF indicator light to alert the driver of the malfunction. This ECU will also store the codes of the malfunctions. The DTC (Diagnostic Trouble Code) can be accessed through the blinking of the height control OFF indicator light by connecting the SST (09843-18040) between the Tc and CG terminals of DLC3 or the use of a hand-held tester. For details, see the 2003 4Runner Repair Manual (Pub. No. RM1001U).

### ► DTC Chart ◀

DTC No.	Detection Item	DTC No.	Detection Item
C1713/ 13	Open or short circuit in right rear height control sensor circuit	C1744/ 44	Open or short circuit in tank solenoid valve circuit
C1714/ 14	Open or short circuit in left rear height control sensor circuit	C1751/ 51	Continuous electric current to height control compressor circuit
C1733/ 33	Open or short circuit in gate solenoid valve circuit	C1761/ 61	ECU malfunction
C1734/ 34	Open or short circuit in leveling solenoid valve circuit	C1774/ 74	Power voltage drop
C1735/ 35	Open or short circuit in exhaust solenoid valve circuit	C1776/ 76	Speed sensor circuit malfunction
C1741/ 41	Open or short circuit in AIR SUS relay circuit	C1779/ 79	Crankshaft position sensor circuit
C1742/ 42	Lock, open or short circuit in height control compressor circuit	—	—

- The operation of the sensors and the switches can be inspected in the input signals check (test mode). For details, refer to the 2003 4Runner Repair Manual (Pub. No. RM1001U).

### ► DTC Chart of the Input Signal Check (Test Mode) ◀

DTC No.	Detection Item	DTC No.	Detection Item
C1782/ 82	Stop light switch circuit malfunction	C1794/ 94	Right front speed sensor circuit malfunction
C1783/ 83	Door courtesy switch circuit malfunction	C1795/ 95	Left front speed sensor circuit malfunction
C1786/ 86	Height control switch circuit malfunction	C1797/ 97	Crankshaft position sensor circuit malfunction
C1788/ 88	Height control OFF switch circuit malfunction	—	—

- A hand-held tester can use to activate the actuators for inspecting their operation (active test). For details, refer to the 2003 4Runner Repair Manual (Pub. No. RM1001U).

- If a malfunction occurs in any of the sensors or actuators, the suspension control ECU effects the following fail-safe controls:

Item		Description Control	
Height Control Sensor (2)	Malfunction on 1 sensor	<ul style="list-style-type: none"> <li>• Height control is effected only with normal sensor.</li> <li>• Target vehicle height is fixed on the normal.</li> <li>• Height control indicator light stays on N position.</li> <li>• Height select switching operation is prohibited.</li> </ul>	
	Malfunction on 2 sensors	<ul style="list-style-type: none"> <li>• Interrupts height control</li> <li>• Target vehicle height is fixed on the normal.</li> <li>• Height control indicator light stays on N position</li> <li>• Height select switching operation is prohibited.</li> </ul>	
Gate Solenoid Valve	Open/ short	<ul style="list-style-type: none"> <li>• Interrupts height control</li> <li>• Reflash control is prohibited.</li> <li>• Gate solenoid valve OFF (Close)</li> <li>• Height select switching operation is prohibited.</li> </ul>	
Leveling Solenoid Valve	Open/ short	<ul style="list-style-type: none"> <li>• Interrupts height control</li> <li>• Height select switching operation is prohibited.</li> </ul>	
Exhaust Solenoid Valve	Open/ short	<ul style="list-style-type: none"> <li>• Prohibits height control after the vehicle reaches its normal vehicle height.</li> <li>• Target vehicle height is fixed on the normal.</li> <li>• Exhaust control is prohibited.</li> <li>• Height select switching operation is prohibited.</li> </ul>	
Tank Solenoid Valve	Open/ short	<ul style="list-style-type: none"> <li>• Exhaust control is prohibited.</li> </ul>	
Motor Relay Coil	Open/ short	<ul style="list-style-type: none"> <li>• Prohibits height control after the vehicle is lowered to its normal vehicle height.</li> <li>• Height select switching operation is prohibited.</li> <li>• Vehicle height is fixed on the normal.</li> </ul>	
Compressor Motor	Lock	<ul style="list-style-type: none"> <li>• Prohibits height control after the vehicle is lowered to its normal vehicle height.</li> <li>• Height select switching operation is prohibited.</li> <li>• Vehicle height is fixed on the normal.</li> </ul>	
	Powered continuously or excessively	<ul style="list-style-type: none"> <li>• Prohibits height control after the vehicle is lowered to its normal vehicle height.</li> <li>• Height select switching operation is prohibited.</li> <li>• Vehicle height is fixed on the normal.</li> </ul>	
Speed Sensor (2)	Malfunction on 1 sensor	Low Speed Range	<ul style="list-style-type: none"> <li>• Height control is effected with normal sensor, with no difference between the right and left.</li> <li>• Reflash control is prohibited.</li> </ul>
		High Speed Range	<ul style="list-style-type: none"> <li>• Reflash control is prohibited.</li> <li>• Gate solenoid valve OFF (Close)</li> </ul>
	Malfunction on 2 sensors	<ul style="list-style-type: none"> <li>• Effects height control as high speed driving.</li> <li>• Height select switching operation is prohibited.</li> <li>• Vehicle height is fixed on the normal.</li> <li>• Reflash control is prohibited.</li> <li>• Gate solenoid valve OFF (Close)</li> </ul>	
Engine Speed Signal from ECM	Low Speed Range	<ul style="list-style-type: none"> <li>• Height select switching operation is prohibited.</li> <li>• Vehicle height is fixed on the normal.</li> <li>• Reflash control is prohibited.</li> <li>• Gate solenoid valve OFF (Close)</li> </ul>	
	High Speed Range	Engine speed is fixed 1000 rpm	