

Cruise Control (2UZ-FE)

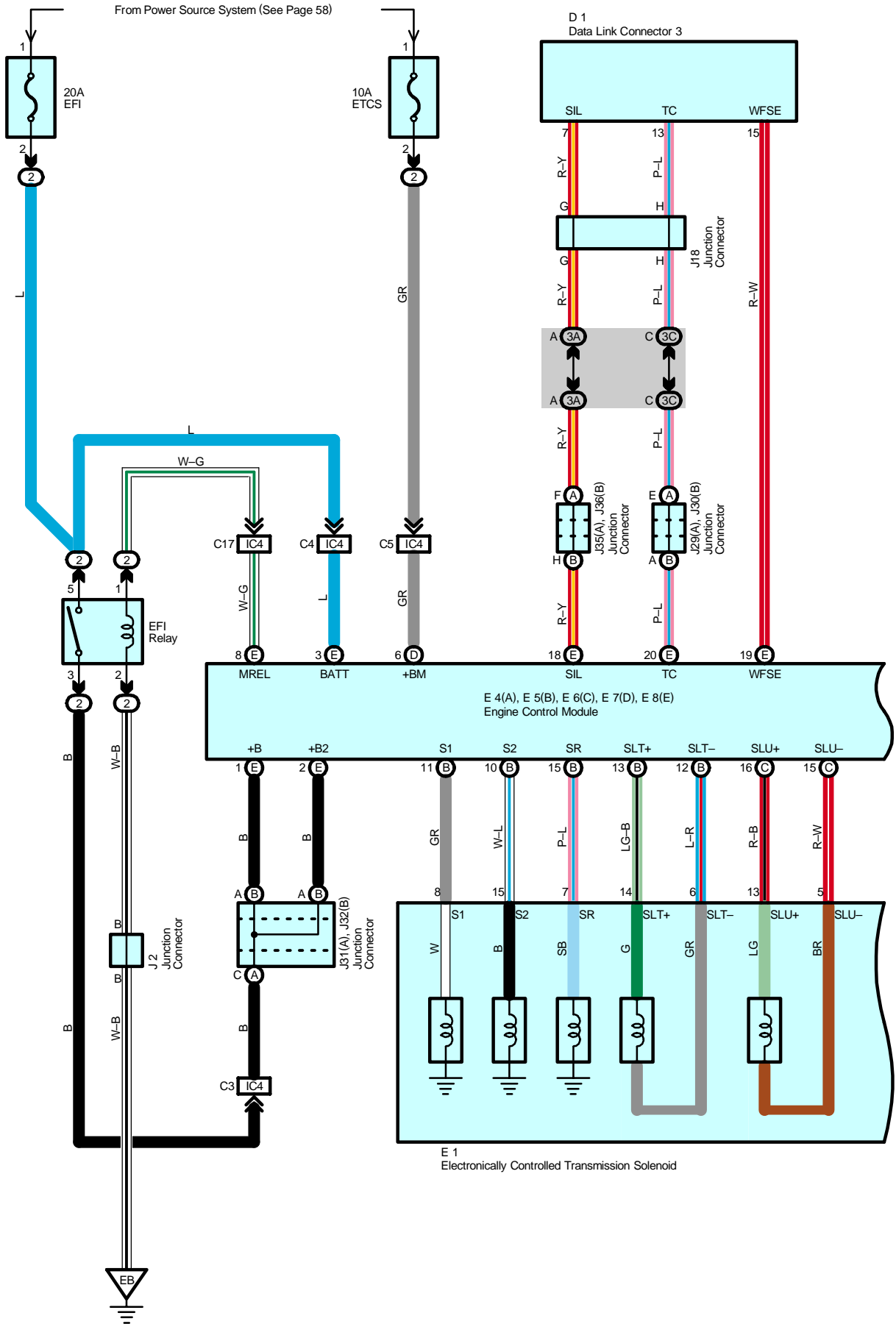

From Power Source System (See Page 58)

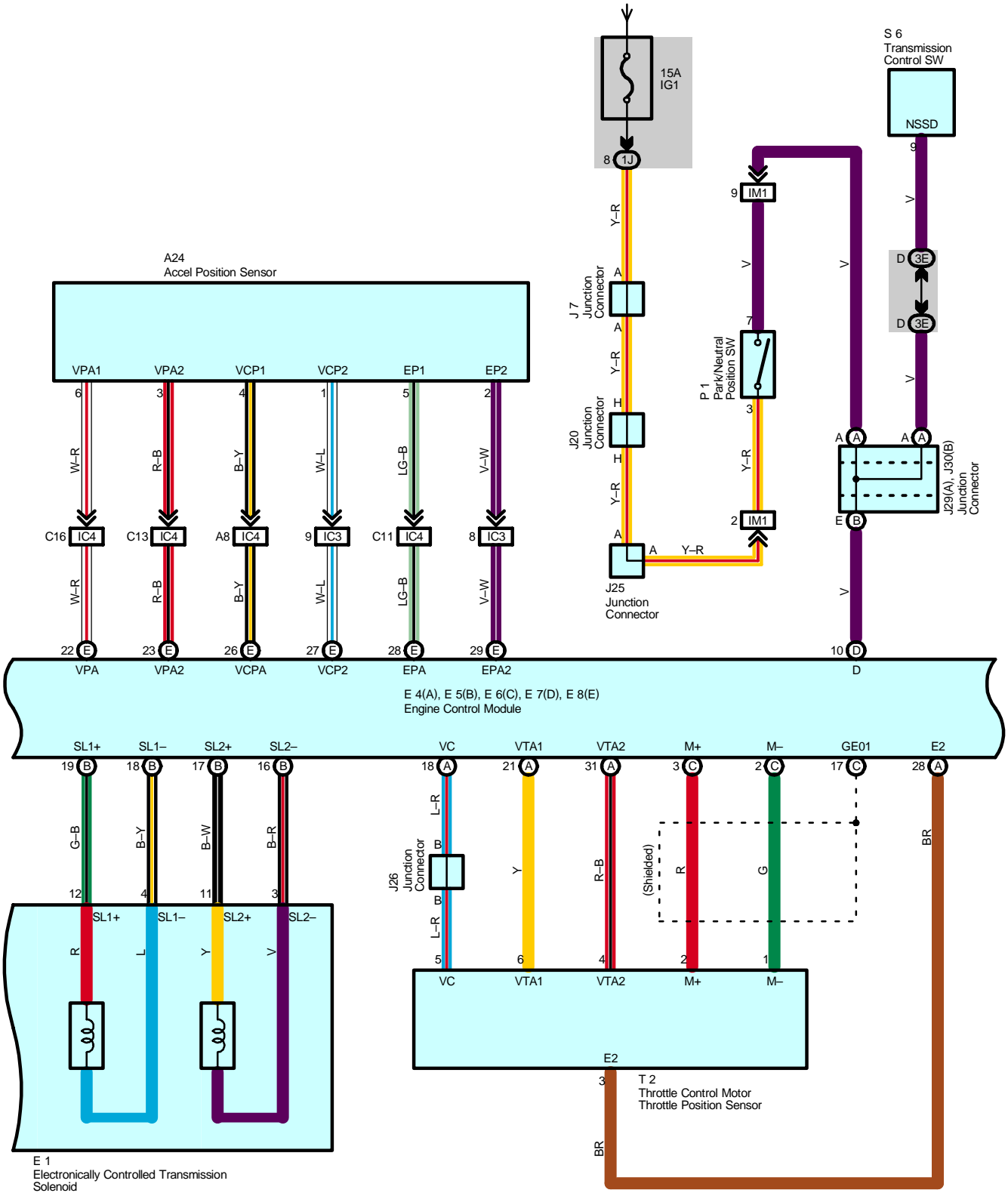

E 1
Electronically Controlled Transmission Solenoid

T 2
Throttle Control Motor
Throttle Position Sensor

From Power Source System (See Page 58)

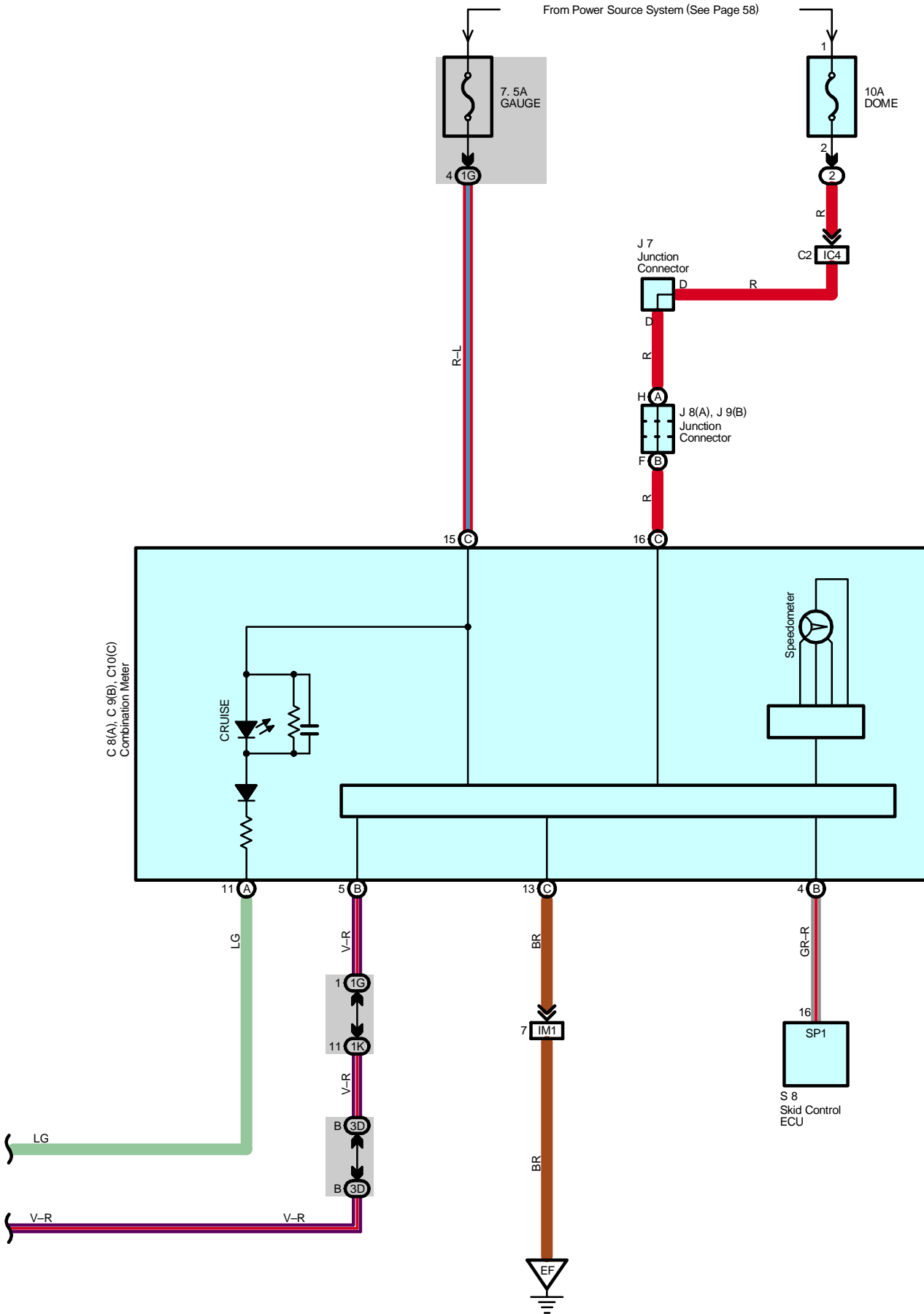

Cruise Control (2UZ-FE)

System Outline

The cruise control system is a constant vehicle speed controller in which control of the switch on the instrument panel makes it possible to automatically adjust the opening of the engine throttle valve without depressing of the accel pedal.

1. Set Operation

When the ON-OFF SW is turned on, the system starts preparations necessary for the cruise control and turns on the indicator light in the combination meter.

2. Set Speed Control

When the - SET SW is operated with the cruise control main SW turned on during travelling, the constant vehicle speed is controlled.

3. Coast Control

When the - SET SW is kept turned on during cruise control travelling, the engine control module controls the throttle valve to decelerate the vehicle. Every time the - SET SW is turned on instantaneously, the vehicle speed is decelerated approximately 1.5 km/h.

4. Accel Control

When the + RES SW is kept turned on during cruise control travelling, the engine control module controls the throttle valve to accelerate the vehicle. Every time the + RES SW is turned on instantaneously, the vehicle speed is accelerated approximately 1.5 km/h.

5. Resume Control

When the vehicle speed is within the low speed limit (Approximately 40 km/h, 25 mph) if the cruise control is cancelled, use of the + RES SW accelerates the vehicle to the speed level used before canceling the cruise control.

6. Manual Cancel Mechanism

If any of the following signals is input during cruise control travelling, the cruise control is cancelled.

- * The stop light SW is turned on.
- * The CANCEL SW is turned on.
- * The ON-OFF SW is turned off.

7. Auto Cancel Function

If any of the following conditions is encountered, the cruise control is automatically cancelled.

- * The stop light SW wiring is faulty or short-circuited.
- * The vehicle speed signal is faulty.
- * The electronically controlled throttle malfunctions.

8. Overdrive Control Function

Overdrive is sometimes cut off on gradients during cruise control driving. When end of climbing gradient is determined by throttle opening degree information after overdrive is canceled, control is reset to overdrive condition after overdrive resetting timer operation. Also, when overdrive is cut off during accelerator resuming control, control is reset to overdrive condition when accelerator resuming control is finished.

Service Hints

E4 (A), E5 (B), E6 (C), E7 (D), E8 (E) Engine Control Module

- (E) 9-Ground : Approx. 12 volts with ignition SW at ON position
- (D) 6, (E) 3-Ground : Always approx. 12 volts
- (A) 6, (A) 7, (B) 8, (C) 1, (C) 4, (C) 7, (D) 1, (E) 15-Ground : Always continuity
- (D)19-Ground : Approx. 12 volts with brake pedal depressed
- (D)24-Ground : Continuity with cruise control ON-OFF SW at on
 - Approx. 1540 Ω with CANCEL SW on in cruise control SW
 - Approx. 240 Ω with + RES SW on in cruise control SW
 - Approx. 630 Ω with - SET SW on in cruise control SW

C13 Combination SW

- 5-4 : Approx. 1540 Ω with CANCEL SW on
 - Approx. 240 Ω with + RES SW on
 - Approx. 630 Ω with - SET SW on

 : **Parts Location**

Code	See Page	Code	See Page	Code	See Page
A24	36	J2	33 (2UZ-FE)	J32	B 38
C8	A 37	J4	38	J33	A 38
C9	B 37	J7	38	J34	B 38
C10	C 37	J8	A 38	J35	A 38
C13	37	J9	B 38	J36	B 38
D1	37	J18	38	J37	38
E1	32 (2UZ-FE)	J20	38	P1	33 (2UZ-FE)
E4	A 37	J25	38	S6	39
E5	B 37	J26	38	S8	39
E6	C 37	J29	A 38	S12	39
E7	D 37	J30	B 38	T2	33 (2UZ-FE)
E8	E 37	J31	A 38		

 : **Relay Blocks**

Code	See Page	Relay Blocks (Relay Block Location)
2	22	Engine Room R/B (Engine Compartment Left)

 : **Junction Block and Wire Harness Connector**

Code	See Page	Junction Block and Wire Harness (Connector Location)
1E	24	Engine Room Main Wire and Driver Side J/B (Lower Finish Panel)
1G	25	Instrument Panel Wire and Driver Side J/B (Lower Finish Panel)
1J		
1K		
3A	28	Instrument Panel Wire and Center J/B (Instrument Panel Brace RH)
3C		
3D		
3E		

 : **Connector Joining Wire Harness and Wire Harness**

Code	See Page	Joining Wire Harness and Wire Harness (Connector Location)
IC3	48	Instrument Panel Wire and Engine Room Main Wire (Left Kick Panel)
IC4		
IL1	50	Instrument Panel Wire and Instrument Panel Wire (Right Upper Side of the Glove Box)
IM1	52	Engine Wire and Instrument Panel Wire (Right Side of Blower Unit)
IM2		

 : **Ground Points**

Code	See Page	Ground Points Location
EB	44 (2UZ-FE)	Front Left Fender
EE	44 (2UZ-FE)	Rear Side of Right Bank Cylinder Block
EF	44 (2UZ-FE)	Rear Side of Left Bank Cylinder Block
IK	48	Right Kick Panel