

From Power Source System (See Page 58)

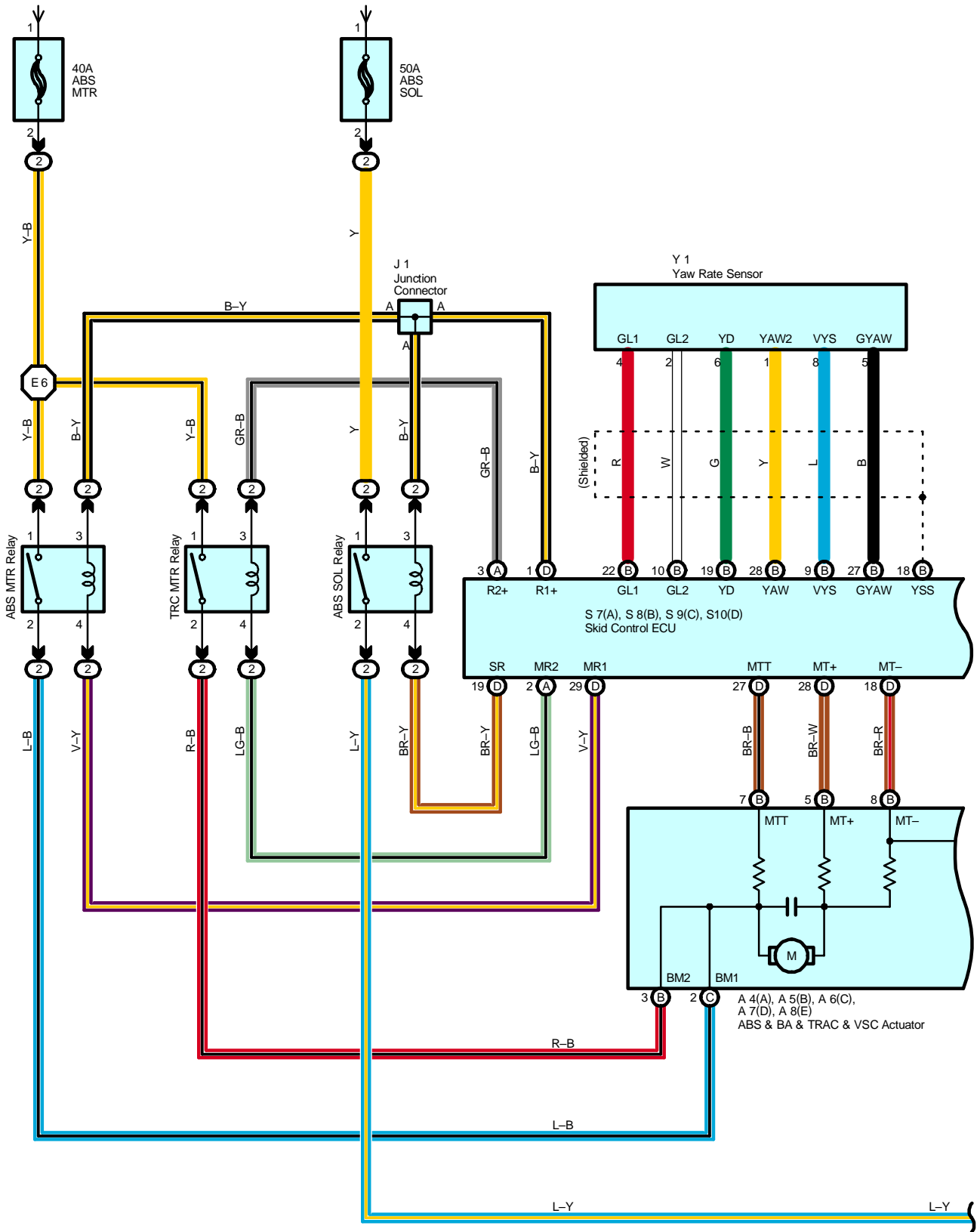

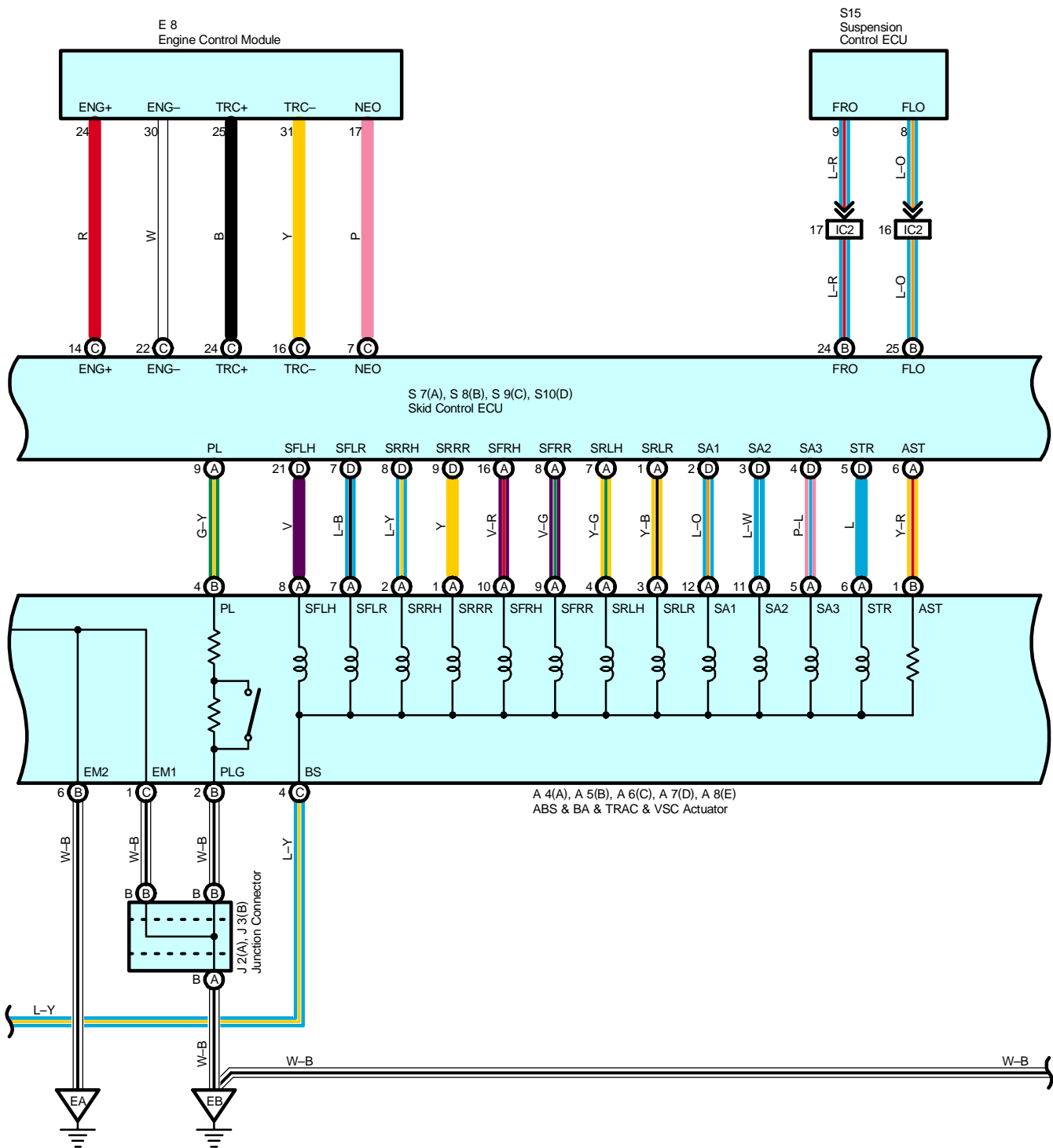

- \* 1 : Except 1GR-FE 2WD
- \* 2 : Except 1GR-FE 4WD
- \* 3 : 1GR-FE 4WD
- \* 4 : 1GR-FE 2WD

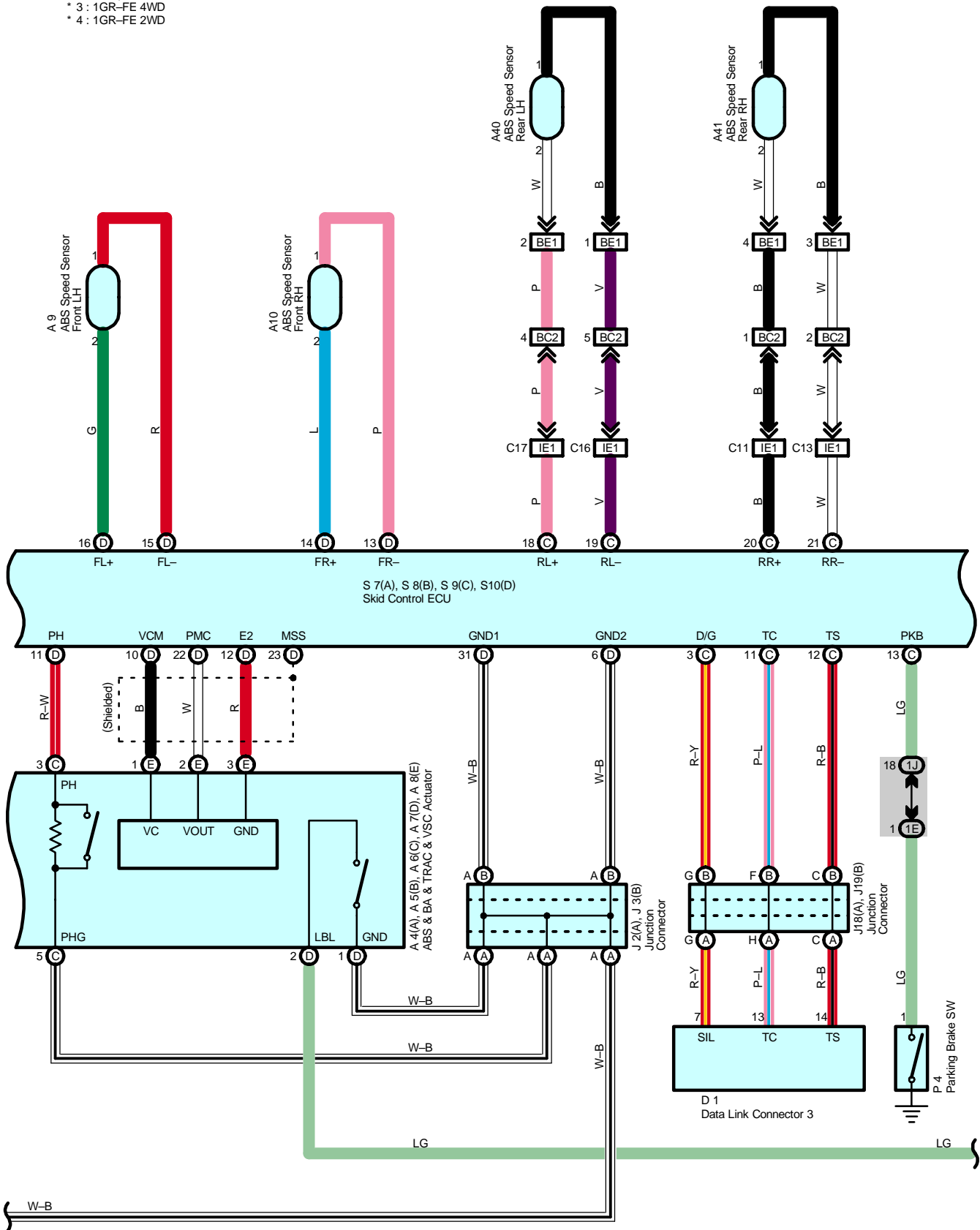

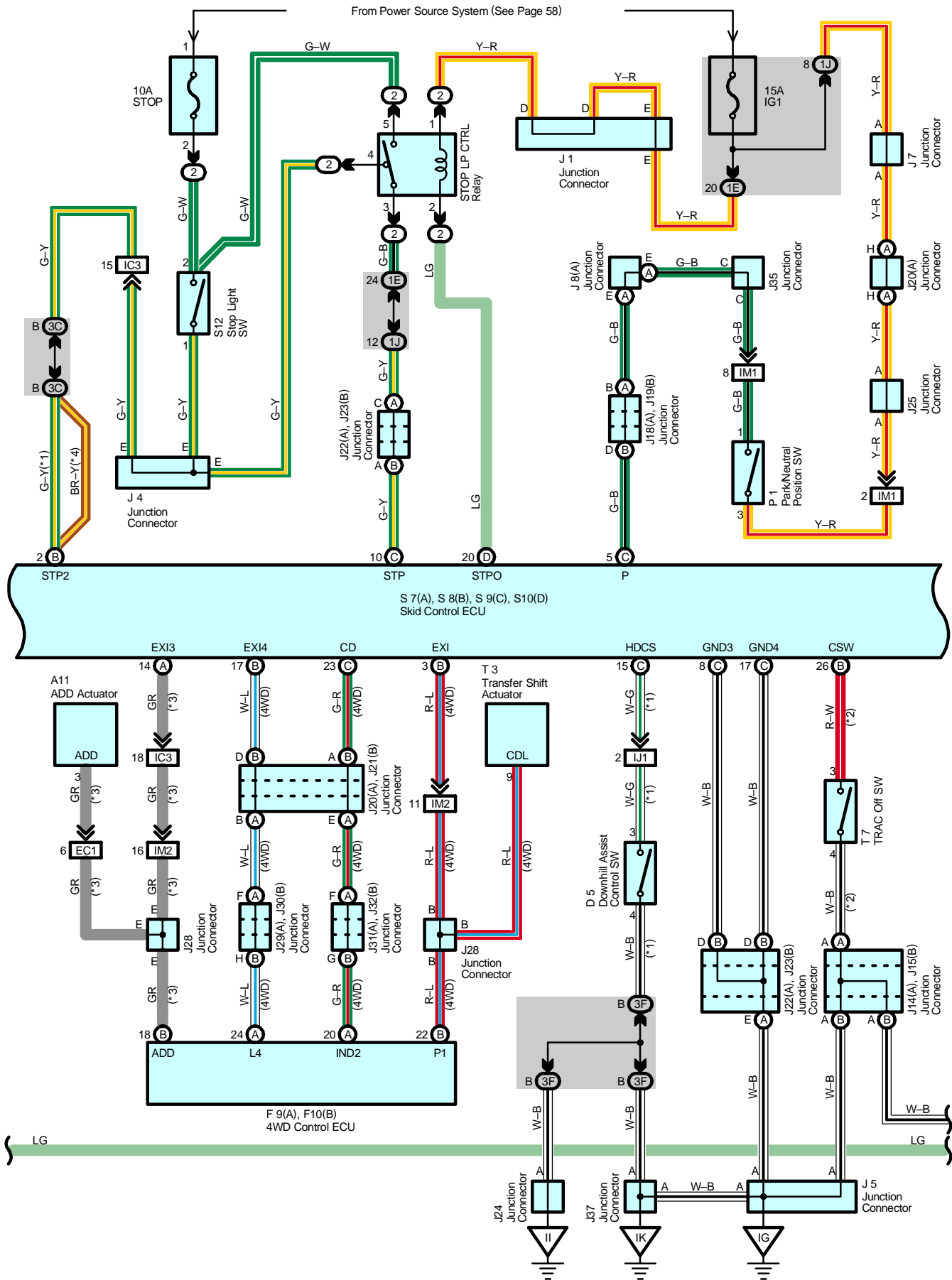

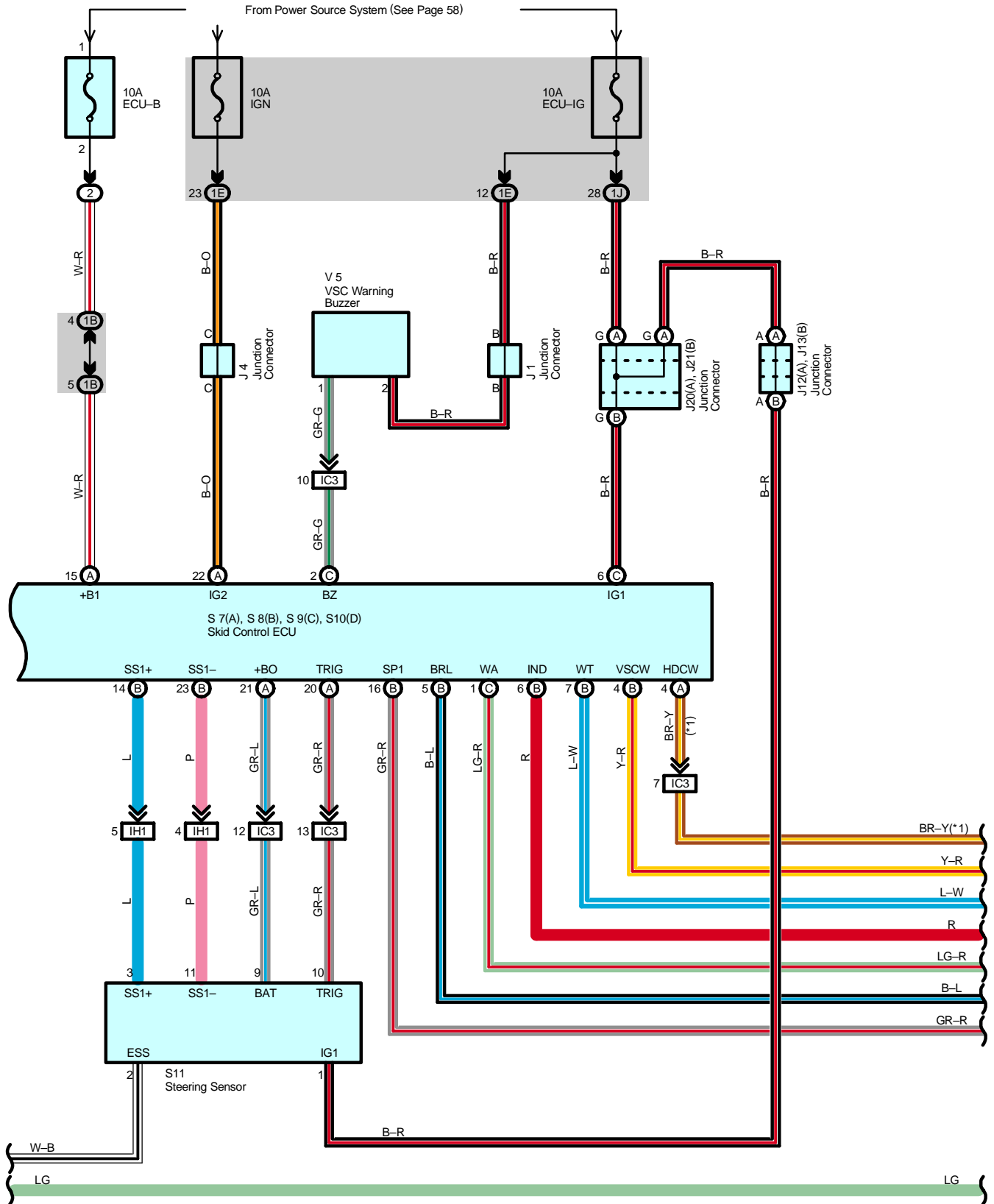



## System Outline

### 1. Normal Operation

The VSC system helps prevent the vehicle from slipping sideways as a result of strong front wheel skid or strong rear wheel skid during cornering.

The followings are two examples that can be considered as circumstances in which the tires exceed their lateral grip limit. The VSC system is designed to help control the vehicle behavior by controlling the engine's output and the brakes at each wheel when the vehicle is under one of the conditions indicated below.

- \* When the front wheels lose grip in relation to the rear wheels (Strong front wheel skid tendency).
- \* When the rear wheels lose grip in relation to the front wheels (Strong rear wheel skid tendency).

### 2. Downhill Assist Control Operation

The downhill assist control operation controls braking action of each wheel to help prevent out-of-balance vehicle posture when descending a steep hill or traveling at a speed exceeding the threshold of wheel gripping capability. When the downhill assist control is in operation, the brake system controls vehicle speed within the range of 5 to 7 km/h.

For the downhill assist control to be operative all of the following conditions have to be met:

- \* Downhill assist control switch = ON
- \* Transfer L4 selected
- \* Vehicle speed is 5 km/h or more, but less than 25 km/h.
- \* Accelerator pedal OFF
- \* Brake pedal OFF

### 3. Hill-Start Support Control Operation

When starting on a steep hill for ascending, the hill-start support control automatically puts the brake on momentarily – from the moment when the driver releases his foot from the brake pedal until he steps on the accelerator pedal – to help the driver start the vehicle safely and smoothly.

Please bear in mind, however, that it activates the brake system for only 3 seconds.

For the hill-start support control to be operative all of the following conditions have to be met:

- \* Shift position = D, 2, or L
- \* Vehicle not moving forward with some wheel(s) slipping
- \* Vehicle speed > 0 km/h

## ○ : Parts Location

Code		See Page	Code		See Page	Code		See Page
A4	A	32 (2UZ-FE)	F10	B	37	J28		38
		34 (1GR-FE)	J1		33 (2UZ-FE)	J29	A	38
A5	B	32 (2UZ-FE)			J2		35 (1GR-FE)	J30
		34 (1GR-FE)	33 (2UZ-FE)	J31			A	38
A6	C	32 (2UZ-FE)	J3		35 (1GR-FE)	J32	B	38
		34 (1GR-FE)			33 (2UZ-FE)	J35		38
A7	D	32 (2UZ-FE)	J4		35 (1GR-FE)	J37		38
		34 (1GR-FE)			38	P1		33 (2UZ-FE)
A8	E	32 (2UZ-FE)	J5		38			P4
		34 (1GR-FE)	J7		38			
A9		32 (2UZ-FE)	J8	A	38	S7	A	39
		34 (1GR-FE)	J9	B	38	S8	B	39
A10		32 (2UZ-FE)	J12	A	38	S9	C	39
		34 (1GR-FE)	J13	B	38	S10	D	39
A11		34 (1GR-FE)	J14	A	38	S11		39
A40		40	J15	B	38	S12		39
A41		40	J18	A	38	S15		39
C9	B	37	J19	B	38	T3		33 (2UZ-FE)
C10	C	37	J20	A	38			35 (1GR-FE)
C11	D	37	J21	B	38	T7		39
D1		37	J22	A	38	V5		39
D5		37	J23	B	38	Y1		39
E8		37	J24		38			
F9	A	37	J25		38			

 : **Relay Blocks**

Code	See Page	Relay Blocks (Relay Block Location)
2	<a href="#">22</a>	Engine Room R/B (Engine Compartment Left)

 : **Junction Block and Wire Harness Connector**

Code	See Page	Junction Block and Wire Harness (Connector Location)
1B	<a href="#">24</a>	Engine Room Main Wire and Driver Side J/B (Lower Finish Panel)
1E		
1G	<a href="#">25</a>	Instrument Panel Wire and Driver Side J/B (Lower Finish Panel)
1J		
3C	<a href="#">28</a>	Instrument Panel Wire and Center J/B (Instrument Panel Brace RH)
3F		

 : **Connector Joining Wire Harness and Wire Harness**

Code	See Page	Joining Wire Harness and Wire Harness (Connector Location)
EC1	<a href="#">46 (1GR-FE)</a>	Engine Wire and Differential Wire (Near the Front Differential)
IC2	<a href="#">48</a>	Instrument Panel Wire and Engine Room Main Wire (Left Kick Panel)
IC3		
IC4		
IE1	<a href="#">50</a>	Instrument Panel Wire and Floor No.2 Wire (Left Kick Panel)
IH1	<a href="#">50</a>	Instrument Panel Wire and Instrument Panel Wire (Behind the Combination Meter)
IJ1	<a href="#">50</a>	Instrument Panel Wire and Instrument Panel Wire (Instrument Panel Brace RH)
IM1	<a href="#">52</a>	Engine Wire and Instrument Panel Wire (Right Side of Blower Unit)
IM2		
BC2	<a href="#">54</a>	Frame Wire and Floor No.2 Wire (Under the Rear LH Seat)
BE1	<a href="#">54</a>	Frame Wire and Skid Control Sensor Wire (Right Side of No.5 Crossmember)

 : **Ground Points**

Code	See Page	Ground Points Location
EA	<a href="#">44 (2UZ-FE)</a>	Front Right Fender
	<a href="#">46 (1GR-FE)</a>	
EB	<a href="#">44 (2UZ-FE)</a>	Front Left Fender
	<a href="#">46 (1GR-FE)</a>	
EF	<a href="#">44 (2UZ-FE)</a>	Rear Side of Left Bank Cylinder Block
	<a href="#">46 (1GR-FE)</a>	
IG	<a href="#">48</a>	Left Kick Panel
II	<a href="#">48</a>	Instrument Panel Brace RH
IK	<a href="#">48</a>	Right Kick Panel

 : **Splice Points**

Code	See Page	Wire Harness with Splice Points	Code	See Page	Wire Harness with Splice Points
E6	<a href="#">44 (2UZ-FE)</a>	Engine Room Main Wire	E6	<a href="#">46 (1GR-FE)</a>	Engine Room Main Wire