

NOTICE: When inspecting or repairing the SRS, perform the operation in accordance with the following precautionary instructions and the procedure and precautions in the Repair Manual for the applicable model year.

- Malfunction symptoms of the SRS are difficult to confirm, so the DTCs become the most important source of information when troubleshooting. When troubleshooting the SRS, always inspect the DTCs before disconnecting the battery.
- **Work must be started after 90 seconds from when the ignition switch is turned to the "LOCK" position and the negative (-) terminal cable is disconnected from the battery.**
(The SRS is equipped with a back-up power source so that if work is started within 90 seconds from disconnecting the negative (-) terminal cable of the battery, the SRS may be deployed.)
- When the negative (-) terminal cable is disconnected from the battery, the memory of the clock and audio system will be canceled. So before starting work, make a record of the contents memorized in the audio memory system. When work is finished, reset the audio systems as they were before and adjust the clock. This vehicle has power tilt and power telescopic steering, power seat and power outside rear view mirror which are all equipped with memory function. However, it is not possible to make a record of the memory contents. So when the work is finished, it will be necessary to explain this fact to the customer, and ask the customer to adjust the features and reset the memory. To avoid erasing the memory in each memory system, never use a back-up power supply from outside the vehicle.
- Before repairs, remove the airbag sensor if shocks are likely to be applied to the sensor during repairs.
- Do not expose the steering wheel pad, front passenger airbag assembly, side airbag assembly, curtain shield airbag assembly, seat belt pretensioner, front airbag sensor assembly, airbag sensor assembly or side airbag sensor assembly directly to hot air or flames.
- Even in cases of a minor collision where the SRS does not deploy, the steering wheel pad, front passenger airbag assembly, side airbag assembly, curtain shield airbag assembly, seat belt pretensioner, front airbag sensor assembly, airbag sensor assembly and side airbag sensor assembly should be inspected.
- Never use SRS parts from another vehicle. When replacing parts, replace them with new parts.
- Never disassemble and repair the steering wheel pad, front passenger airbag assembly, side airbag assembly, curtain shield airbag assembly, seat belt pretensioner, front airbag sensor assembly, airbag sensor assembly or side airbag sensor assembly in order to reuse it.
- If the steering wheel pad, front passenger airbag assembly, side airbag assembly, curtain shield airbag assembly, seat belt pretensioner, front airbag sensor assembly, airbag sensor assembly or side airbag sensor assembly has been dropped, or if there are cracks, dents or other defects in the case, bracket or connector, replace them with new ones.
- Use a volt/ohmmeter with high impedance (10 k Ω /V minimum) for troubleshooting the system's electrical circuits.
- Information labels are attached to the periphery of the SRS components. Follow the instructions on the notices.
- After work on the SRS is completed, perform the SRS warning light check.
- If the vehicle is equipped with a mobile communication system, refer to the precaution in the IN section of the Repair Manual.

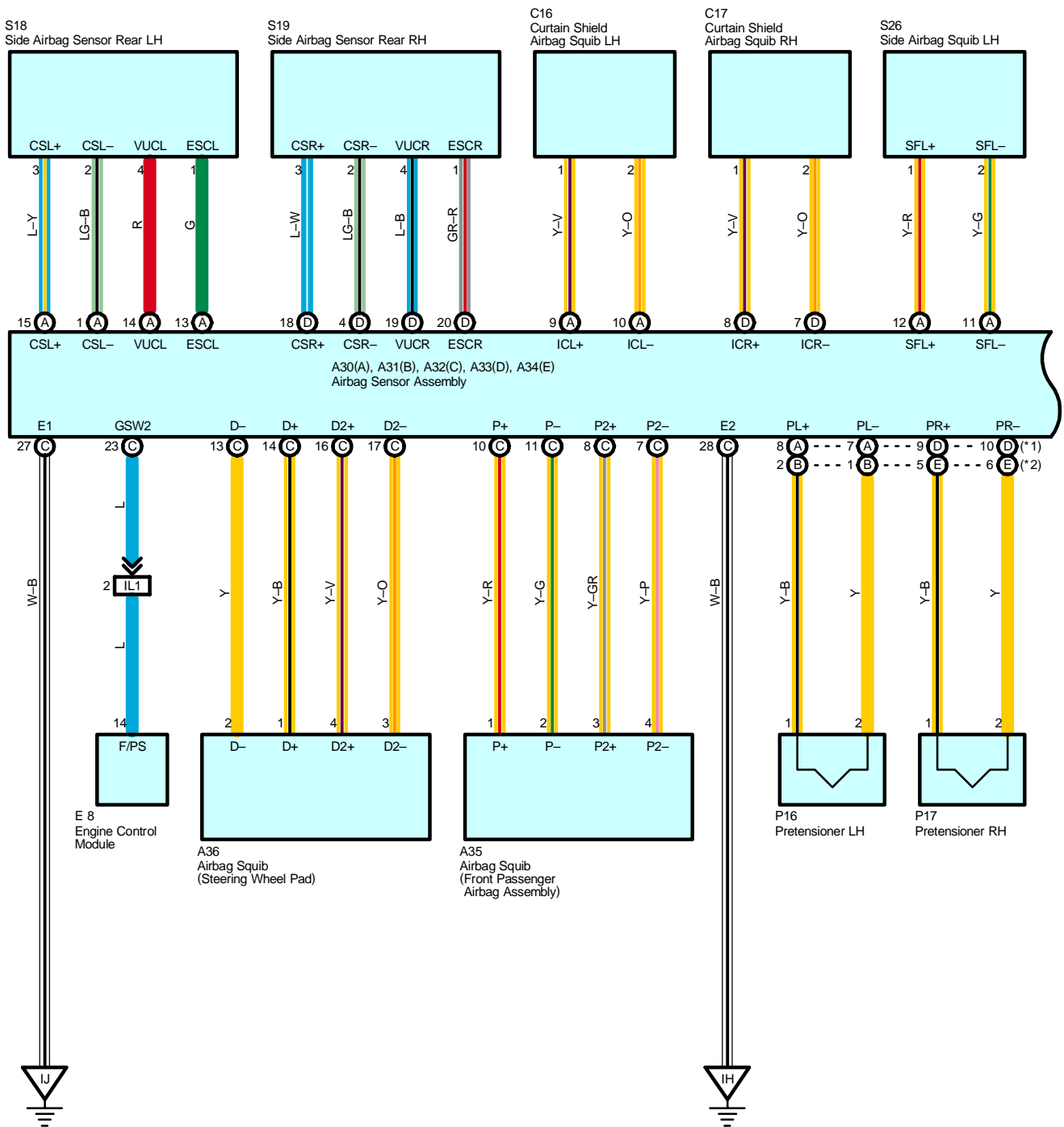

From Power Source System (See Page 58)

* 1 : w/ Side Airbag
 * 2 : w/o Side Airbag

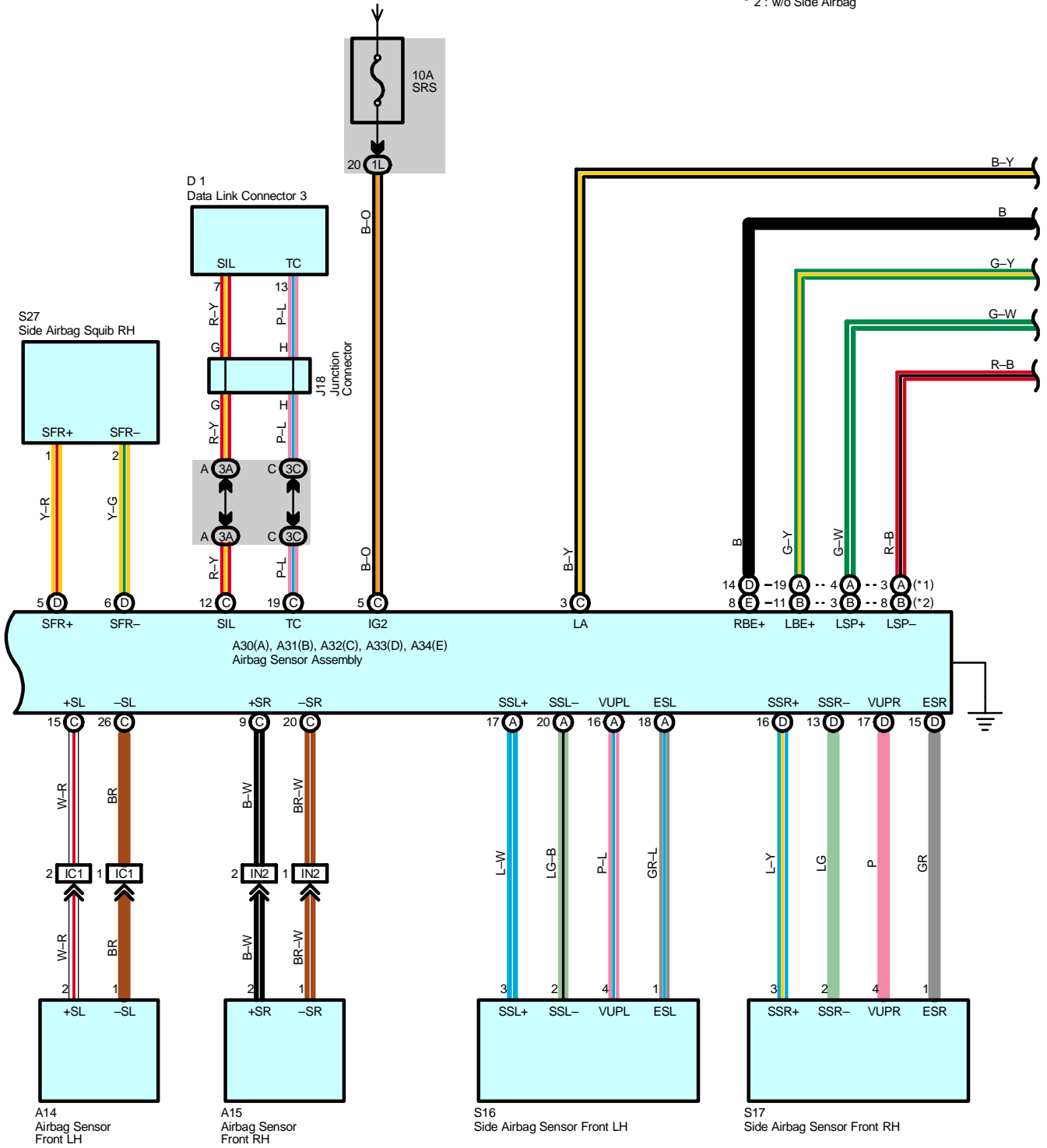

From Power Source System (See Page 58)

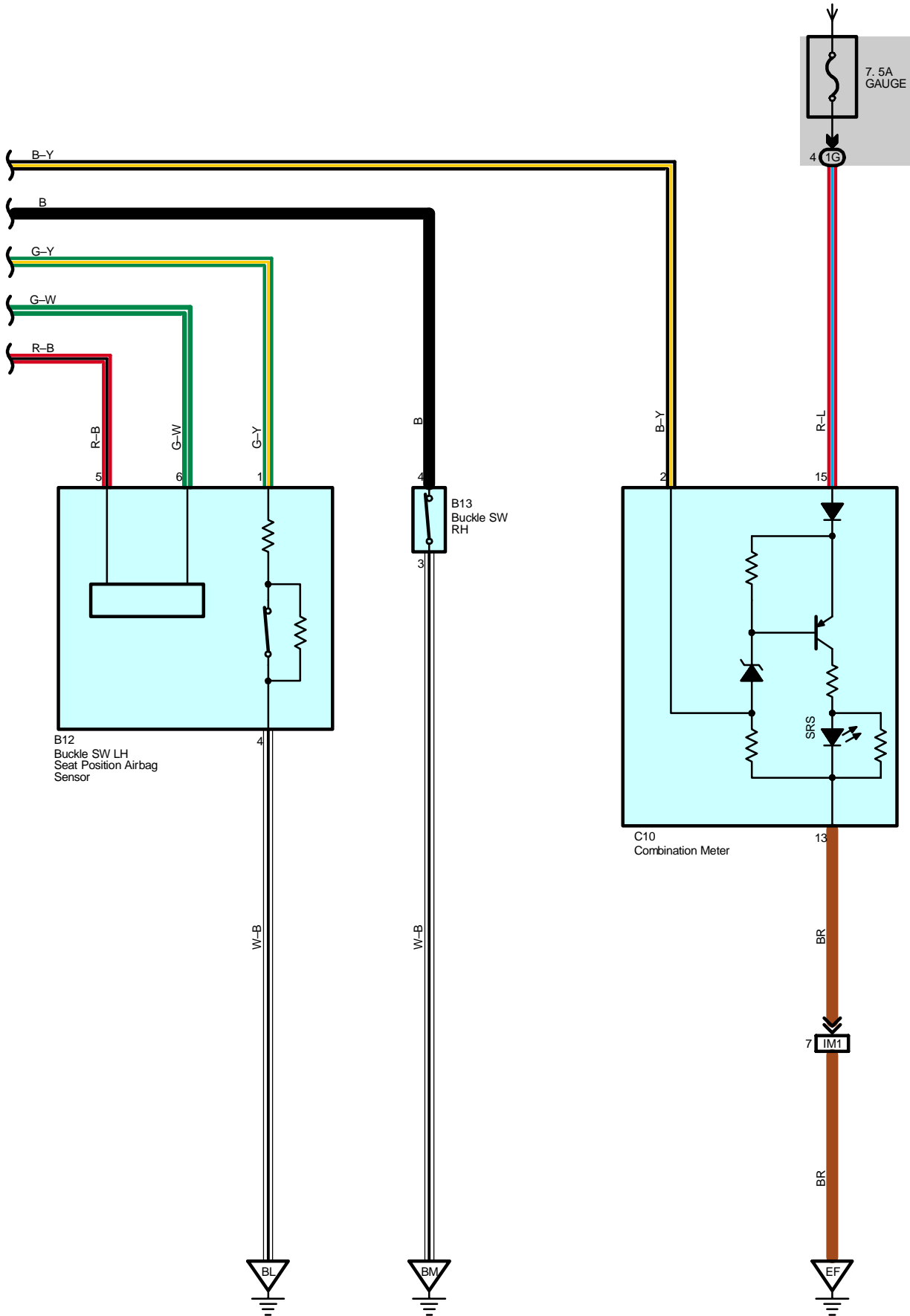

System Outline

The SRS is a driver and front passenger protection device which has a supplemental role to the seat belts. When the ignition SW is turned to ON, the current from the SRS fuse flows to TERMINAL (C) 5 of the airbag sensor assembly.

If an accident occurs while driving, when the frontal impact exceeds a set level, the current from the SRS fuse flows to TERMINALS (C) 14, (C) 16, (C) 10, (C) 8, (A) 8 (w/ side airbag) or (B) 2 (w/o side airbag) and (D) 9 (w/ side airbag) or (E) 5 (w/o side airbag) of the airbag sensor assembly to the airbag squibs and the pretensioners to TERMINALS (C) 13, (C) 17, (C) 11, (C) 7, (A) 7 (w/ side airbag) or (B) 1 (w/o side airbag) and (D) 10 (w/ side airbag) or (E) 6 (w/o side airbag) of the airbag sensor assembly to TERMINAL (C) 27, (C) 28 or BODY GROUND to GROUND, so that current flows to the airbag squibs and the pretensioners and causes them to operate.

When the side impact also exceeds a set level, the current from the SRS fuse flows to TERMINALS (A) 12, (D) 5, (A) 9 and (D) 8 of the airbag sensor assembly to the side airbag squibs and the curtain shield airbag squibs TERMINALS (A) 11, (D) 6, (A) 10 and (D) 7 of the airbag sensor assembly to TERMINAL (C) 27, (C) 28 or BODY GROUND to GROUND, causing side airbag squibs and curtain shield airbag squibs to operate.

The airbag stored inside the steering wheel pad is instantaneously expanded to soften the shock to the driver.

The airbag stored inside the passenger's instrument panel is instantaneously expanded to soften the shock to the front passenger.

Side airbags are instantaneously expanded to soften the shock of side to the driver and front passenger.

The curtain shield airbag can ease an impact on the head of the front and rear passengers and reduce risks of injury.

The pretensioners make sure of the seat belt restrainability.

○ : Parts Location

Code		See Page	Code	See Page	Code	See Page
A14		32 (2UZ-FE)	A35	36	J18	38
		34 (1GR-FE)	A36	36	P16	41
A15		32 (2UZ-FE)	B12	42	P17	41
		34 (1GR-FE)	B13	42	S16	41
A30	A	36	C10	37	S17	41
A31	B	36	C16	40	S18	41
A32	C	36	C17	40	S19	41
A33	D	36	D1	37	S26	42
A34	E	36	E8	37	S27	42

○ : Junction Block and Wire Harness Connector

Code	See Page	Junction Block and Wire Harness (Connector Location)
1G	25	Instrument Panel Wire and Driver Side J/B (Lower Finish Panel)
1L		
3A	28	Instrument Panel Wire and Center J/B (Instrument Panel Brace RH)
3C		

□ : Connector Joining Wire Harness and Wire Harness

Code	See Page	Joining Wire Harness and Wire Harness (Connector Location)
IC1	48	Instrument Panel Wire and Engine Room Main Wire (Left Kick Panel)
IL1	50	Instrument Panel Wire and Instrument Panel Wire (Right Upper Side of the Glove Box)
IM1	52	Engine Wire and Instrument Panel Wire (Right Side of Blower Unit)
IN2	52	Instrument Panel Wire and Engine Room Main Wire (Right Kick Panel)

▽ : Ground Points

Code	See Page	Ground Points Location
EF	44 (2UZ-FE)	Rear Side of Left Bank Cylinder Block
	46 (1GR-FE)	
IH	48	Instrument Panel Brace LH
IJ	48	Instrument Panel Brace RH
BL	54	Floor Seat Crossmember LH
BM	54	Floor Seat Crossmember RH